

73  
MAY  
1989elektor **INDIA**168  
Rs. 10.00

# electronics

THE MAGAZINE FOR PROFESSIONALS



- TELECOM, A MUST IN ELECTION MANIFESTO ■ THE BUGGING STORY OF INFORMATION ■ VIDEO RECORDING AMPLIFIER ■ DYNAMIC RANGE PROCESSOR
- MULTI-POINT IR CONTROL ■ CLASS-D AMPLIFIER

RES &amp; TRANS I

RES &amp; TRANS I

RES &amp; TRANS I

If your child  
is a **CHIP** of  
the **OLD BLOCK**,

He deserves

# RES & TRANS I

The Electronic Comic-Books

in *Electro Technology*

From the publishers of **elektor**

~~ORIGINAL PRICE~~

~~PART ONE  
Rs. 90.00~~

~~PART TWO  
Rs. 70.00~~

**SPECIAL PRICE**

PART ONE Rs. 35.00

PART TWO Rs. 35.00

PCB PRICE Rs. 20.00

**RES & TRANS I**  
**HANDS OFF MY BIKE!!**

IT'S GOT AN ELECTRONIC ALARM!

**RES & TRANS I**  
**BANISH THE MYSTERIES OF ELECTRONICS**



## RESI & TRANS I

### BANISH THE MYSTERIES OF ELECTRONICS!

In the course of the book, they explain how to build a few practical circuits, a continuity tester, a morse code, bleeps & an amplifier.

A Printed Circuit Board is included to simplify the actual construction as well as an extremely useful gadget, The Resimeter

## RESI & TRANS II

### Hands of my Bike!!

Electronics & Cartoons?

Why not? In this, their Second Book Resi & Transi set about building an Electronics Alarm with a powerful siren to protect a bike, motorbike, car or even a house. And, as usual they are totally indifferent to the normal code of practice of electronic components. But then, who ever said the electronics has to be dull? Resi & Transi make ELECTRONICS easy ... and fun.

Send full payment by M.O./P.O./D.D. No  
Cheque Please. to:

**precious<sup>®</sup>**  
ELECTRONICS CORPORATION

52-C, Proctor Road, Bombay-400 007  
Ph. 367459, 369478 Telex-(011) 76661  
ELEK IN

RES &amp; TRANS I

RES &amp; TRANS I

**Publisher:** C.R. Chandarana  
**Editor:** Surendra Iyer  
**Technical Adviser:** Ashok Dongre  
**Circulation/Advertising:** J. Dhas  
**Production:** C.N. Mithagari

**Address:**  
ELEKTOR ELECTRONICS PVT. LTD.  
52, C Proctor Road, Bombay-400 007 INDIA  
Telex: (011) 76661 ELEK IN

**Overseas editions:**

**Elektor Electronics**  
1, Harlequin Avenue,  
Great West Road, Brentford TW8, 9EW U.K.  
**Editor:** Len Seymour

**Pulitron Publicacoes Tecnicas Ltda**  
Av Ipiranga 1100, 8º andar CEP01040 Sao Paulo - Brazil  
**Editor:** Juliano Barsali

**Elektor sari**  
Route Nationale, Le Seau; B.P. 53  
59270 Sallieu - France  
**Editors:** D R S Meyer;  
G C P Raedersdorf

**Elektor Verlag GmbH**  
Susterfeld-Strasse 25 100 Aschen - West Germany  
**Editor:** E J A Krempelsauer

**Elektor EPE**  
Karaiskaki 14 16673 Voula - Athens - Greece  
**Editor:** E Xanthoulis

**Elektuur B.V.**  
Peter Treckpoelstraat 24  
6191 VK Beek - the Netherlands  
**Editor:** P E L Keremakers

**Ferreira & Bento Lda**  
R.D. Estefania, 32.1º 1000 Lisboa - Portugal  
**Editor:** Jorge Goncalves

**Inglesk S.A.**  
Plaza Republica Ecuador 2.28016 Madrid-Spain  
**Editor:** A M Ferrer

**In Part:**  
Kedhorn Holdings PTY Ltd Cnr Fox Valley Road &  
Kingle Street Wahroonga NSW 2076 - Australia  
**Editor:** Roger Harrison

**Electronic Press AB**  
Box 63  
182 11 Danderyd - Sweden  
**Editor:** Bill Cedrun

The Circuits are domestic use only. The submission of designs or articles implies permission to the publisher to alter and translate the text and design and to use the contents in other Elektor Publications and activities. The publishers cannot guarantee to return any material submitted to them. Material must be sent to the Holland address (given above). All drawings, photographs, printed circuit boards and articles published in elektor publications are copyright and may not be reproduced or imitated in whole or part without prior written permission of the publishers.

Patent protection may exist in respect of circuit devices, components etc. described in this magazine.

The publishers do not accept responsibility for failing to identify such patent or other protection.



MEMBER

Printed at : Trupti Offset  
Bombay - 400 013

Ph. 4923261, 4921354  
Copyright © 1988 Elektuur B.V.

*Surendra Iyer*

Volume-7 Number-5  
May-1989

# CONTENTS

Editorial	
Optical Computing .....	5.07
Special Features	
Telecom, a must in election manifesto .....	5.10
The bugging story of information .....	5.16
Audio & Hi-Fi	
PROJECT: Class-D amplifier .....	5.31
Horn loading revisited .....	5.53
Application notes	
Dynamic range processor type SSM 2120/2122 .....	5.39
Components	
Practical filter design (4) .....	5.34
Design Ideas	
New circuit protection devices for loudspeaker systems .....	5.36
General Interest	
PROJECT: The digital model train part 3 .....	5.26
PROJECT: Multi-point infra-red remote control .....	5.40
Radio & Television	
PROJECT: Video recording amplifier .....	5.38
PROJECT: High-precision DLF-based locked frequency reference .....	5.48
Science & Technology	
Big strides in molecular electronics research .....	5.46
Information	
Telecom News .....	5.20
Industry News .....	5.21
Electronic News .....	5.23
Guide-Lines	
Classified ads .....	5.74
Index of advertisers .....	5.74

## OPTICAL COMPUTING

The news that Mitsubishi has succeeded in making the world's first optical chip must fill most of us with excitement

Light, or rather photons, is, of course, already being used on a rapidly expanding scale in telecommunications (fibre optics) and in optical memories (compact disc), but not yet in computing. This is not for want of trying, for research into optical computing has been going on for some years in several parts of the world, notably in Japan, the United Kingdom and the United States.

Optical computing is the science and technology of advanced computing for the future, because we are slowly nearing the final limitations of electronic computers. This is because the silicon chips used in current computers have a number of drawbacks: the speed at which electrons can travel through silicon is restricted to  $5 \times 10^5$  m/s; also, it is already becoming more and more difficult to etch ever narrower paths into the silicon chips (which, incidentally, increase the risk of cross-talk); and finally, as they shrink, it becomes harder to keep them cold and operating properly.

Until the Mitsubishi breakthrough, the only hardware developed consisted of (relatively) simple bistable optical devices (BOODs), also called transphasors. The Japanese have succeeded in developing a practical optical bonding technology, so that the device they have made consists of many transphasors bonded three-dimensionally and constructed, with a number of other (electronic) components on to a GaAs substrate measuring only  $3 \times 3$  mm. If these initial reports are substantiated, it appears that the Japanese have succeeded in producing the first building brick for a single-board optical computer.

\* \* \*

### Front cover

People working in isolated areas of the world may be cut off completely from normal means of communication. This portable system, which allows engineers on exploration work, rescue teams, businessmen, reporters, and others whose job takes them 'out in the field' to make clear contact by telephone, or to transmit and receive data, has been developed by Marconi Marine.

Called 'Satpax', the system links - via the satellites of the International Maritime Satellite Organization - to the international telephone and telex network. Marconi claims that it can be used almost anywhere in the world.

### INCREASE IN COVER PRICE

Rising costs, particularly in news-glazed paper, forced us to reluctantly revise the cover price to Rs. 10.00 from this issue onwards.



# THE DIGITAL MODEL TRAIN — PART 3

by T. Wigmore

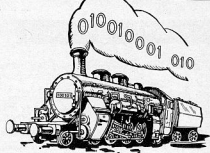

In Part 2 we described the background and design of a locomotive decoder and a two-rail adaptor. This month's instalment is dedicated primarily to the construction of those units, but it will also describe a modification to the decoder involving a different decoder chip.

As we have seen last month, the decoder is designed in surface mount technology (SMT). It is, however, impossible to obtain all components as SMT types. Some ICs, for instance, depend for cooling on their housing and if this becomes too small, a heat sink has to be used, defeating the object of the exercise. Therefore, the decoder is a hybrid circuit. It uses a double-sided PCB that is populated at one side with conventional components and at the other with SMT components.

## Soldering surface-mount components

Working with surface-mount (SMT) components requires rather more dexterity, patience and accuracy than working with conventional components. SMT components must be soldered direct to the printed-circuit board (PCB): IC holders, for instance, are no longer required. Because of that, it is essential that during soldering appropriate precautions are taken to ensure the absence of any electrostatic charges (earthed working surface and soldering bit, for example).

The soldering iron should be rated at about 15–18 W, have temperature control and a fine-pointed bit.

One of the first things that strikes one on a first acquaintance with passive SMT components is that most of them no longer show their value. This makes it essential not to remove them from their packing until they are really required.

Apart from very thin solder, there is also a special solder dispenser on the market that is ideal for soldering SMT components. A new aid is solder in a syringe. This consists of small granules of lead-tin alloy suspended in a semi-liquid paste. When this paste is applied to the solder pad(s), the component terminal(s) may be pressed into the paste, after which it only requires a touch of the hot soldering bit to give a clean joint.

Soldering ICs is done in very much the same way. Note, however, that SMD ICs do not have the usual identification of pin 1. This is located at the most oblique side of the device (see also Fig. 20).

## Construction

The ready-made printed-circuit board consists of four sections; two locomotive boards (double-sided, but not through-plated) and two two-rail adaptor boards (single-sided) as shown in Fig. 18a and 18b respectively. Construction should be started with cutting the PCB into these four sections.

Determine the voltage for the head and tail lights. As stated in Part 2, the standard voltage for the lights is 10 V, which is perfectly satisfactory for 12-V or 16-V bulbs. If the higher supply of 20 V is needed (because 24-V bulbs or two 12-V bulbs in series are used), a hole of 0.8–1 mm dia. must be drilled in the board for pin 9 of IC5. Also, in that case, the through-connection from one side of the board to the other, coinciding with pin 2 of IC3 must NOT be made.

Mount the (only) wire link to the left of IC1 and the four through connections shown in Fig. 19a (with the aid of short lengths of equipment wire). Cut these wires as close as possible to the board, particularly where later IC1 and IC3 will be located, except beside pin 8 of IC1, which should protrude 3–4 mm at the

SMT side.

Select the wanted locomotive address with the aid of Table 3 and install this as shown in Fig. 19b. It is possible to change this afterwards but, owing to the presence of IC1, that will then be a tricky operation.

Solder IC2 and IC3 at the SMT side of the board. Pins 8 of IC2 and 2, 4 and 12 of IC3 coincide with a through connection yet to be made. Bend these pins with a pair of small pliers so that they drop readily into the relevant holes. Before soldering, add a short length of equipment wire that can be soldered at the non-SMT side as well (see Fig. 19c). Note that when a lamp voltage of 20 V is used, the through connection at pin 2 of IC3 must NOT be made.

Mount all components, except the two ICs and Ds, at the non-SMT side of the board. Some conventional components need, none the less, be fitted as if they were SMT types: D1, D2 (if a 1N4148 is used), D3 and the anode of D3b. Bend the terminal wires of these components sharply near the body and cut them close to the body. If the two-rail adaptor is going to be used, the cathode of D3 should protrude about 3 mm at the SMT side; later this will be used as through connection with the adaptor. Capacitors C1 and C3 (beware of the polarity) are bent at right angles over R3 and D1 respectively as shown in Fig. 19d.

Circuits IC1 and IC3 must be soldered direct (no holder) to the board. A number of pins must be shortened, because they must not protrude through the board: pins 1, 2, 3, 4, 9 and 11 of IC1, and pins 1, 7, 9 (not with 20 V lamp voltage), 11 and 14 of IC3. The other pins are soldered at both sides.

Mount Ds at the non-SMT side.

Finally, solder all components at the SMT side of the board. Note that this side also has to house the four (non-SMT) free-wheeling diodes, D1 to D4. The terminals of these diodes, except the cathodes of D3 and D4, should be soldered direct to the board.

#### Parts list

#### LOCOMOTIVE DECODER

All parts surface mount assembly except when marked \*.

#### Resistors ( $\pm 5\%$ ):

R1 = 12K  
R2; R4; R6 = 100K  
R3; R7 = 47K  
R5 = 270K  
R8 = 2K7

#### Capacitors:

C1 = 3n3  
C2 = 10n  
C3 = 470p  
C4 = 10 $\mu$ ; 25 V; tantalum \*  
C5 = 47 $\mu$ ; 6V3; tantalum \*

#### Semiconductors:

D1 = 5V1; 400 mW zener diode \*  
D2 = BAV100  
D3...D6 incl. = 1N4148 \*  
D7...D10 incl. = 1N4001 \*  
IC1 = MC145029 (Motorola) \*  
IC2 = 4060  
IC3 = 4585  
IC4 = 4001  
IC5 = L293 (SGS) or LM 18293 (National Semiconductor) \*

#### TWO-RAIL ADAPTOR

All parts surface-mount assembly

#### Resistors ( $\pm 5\%$ ):

R1; R2 = 1M0  
R3 = 10K  
R4 = 270K

#### Capacitors:

C1 = 1n0  
C2 = 15n  
C3 = 100p  
C4 = 47n

#### Semiconductors:

IC1 = 4030  
IC2 = 4538

#### Miscellaneous:

PCB Type 87291-2/3 (cut in 4 for 2 two-rail adaptors and 2 locomotive decoders).

Fig. 18. Layout and track side of the double-sided (not through-plated) decoder board (a) and those of the single-sided two-rail adaptor board (b).

This concludes the construction of the locomotive decoder board. Construction of the single-sided two-rail adaptor board is straightforward. This board is populated with SMT components only. Before the two boards are sandwiched (if the adaptor board is used), they should be tested together. There are four electrical connections between them that,

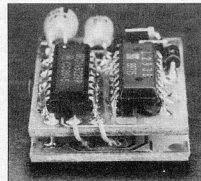
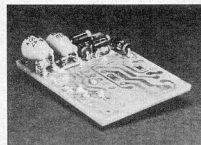
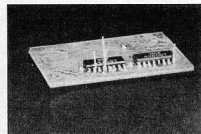
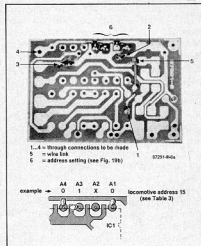
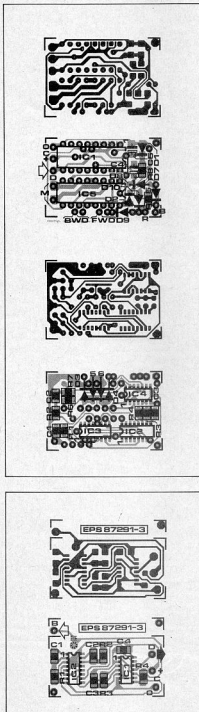

Fig. 19. How to make the through connections (a), but note that only three are made in this photograph; (b) the address setting of pins 1-4 of IC1; (c) the through connections of IC2 and IC3 to the other side of the board; (d) C4 and C5 are bent at right angles across R5 and D1 respectively, while some other components, such as D1, are mounted as SMT elements; (e) the decoder and two-rail adaptor boards are sandwiched.

for test purposes, should be made before some of the wires are cut short. These are: B (made with the cathode terminal of D7 that has been kept long for this purpose); earth (made with the through connection adjacent to pin 8 of IC1); the positive supply line and the data line. The last two should be made with short lengths of equipment wire — see Fig. 19e.

## Installation

The locomotive decoder can be used with d.c. as well as with a.c. locomotives. Actually, the motor of an a.c. locomotive is generally connected as a d.c. motor. The way this is done is shown in Fig. 21. The general wiring diagram of an a.c. motor (here a Marklin type) is shown in Fig. 21a. It is seen that it is connected as a series motor whose stator winding has a centre tap. Which half of the stator winding is used at any one time is determined by the position of the change-over relay (in some models this relay also switches over the lights).

As already discussed, this change-over relay must be removed from Marklin locomotives. Figure 21b shows how two diodes in series with the disconnected terminals of the stator winding convert the a.c. motor to a d.c. motor. The direction of rotation is then dependent on the polarity.

The two motor terminals are connected to the motor output of the decoder (to the right of IC5). The decoupling components, L1, C1, C2, may be retained, but C2, which was connected to earth must now be connected to the '0' line of the decoder.

D.C. motors can be connected to the motor terminals of the decoder without any modifications.

There are various ways of connecting the lights and some of these are shown in Fig. 22. For instance, they may be switched in the positive line (22a) or in the negative line (22b). The former is preferable in view of the somewhat lower dissipation in IC5.

If the lights are required to be independent of the direction of travel, the lamps are connected in series, two by two, direct to the rail voltage as in Fig. 22c. If the lights are preferred in parallel, but are not suitable for 20-V operation, they may be connected to the two La terminals (Fig. 22d). The voltage for the lights must then be set to 10 V as discussed earlier.

When Marklin locomotives are used, it is important that if the lights are connected to the La terminals on the decoder there is no connection between them and the chassis of the locomotive. This means that either the lamp holders must be of the insulated type or the lamps must be connected via an additional diode as shown in Fig. 22e. A drawback of the diode solution is that the lights often have no constant brightness and may flicker from time to time.

If Marklin locomotives are used and the lights are required to be operated independently of the direction of travel, they should be connected as shown in Fig. 22f. They need not be isolated from the locomotive chassis. The brightness may be set by giving the series resistor an appropriate value.

The motor must also be electrically isolated from the locomotive chassis, but

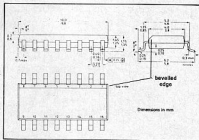

Fig. 20. Pin 1 of an SMD IC is located at the most oblique side.

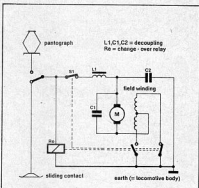

Fig. 21. Circuit diagram of the Marklin motor connections (a); this a.c. motor may be converted for d.c. operation as shown in (b).

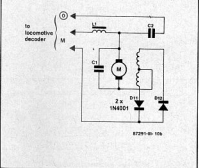

Fig. 21. Circuit diagram of the Marklin motor connections (a); this a.c. motor may be converted for d.c. operation as shown in (b).

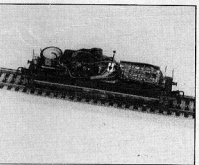
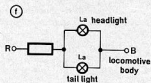
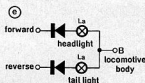
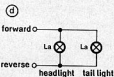
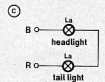
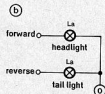
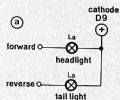

Fig. 23. Decoder (without two-rail adaptor) installed in a Marklin locomotive; the buffer capacitor, where used, is fitted in the back of the locomotive. The arrow points to the shrink-sleeved diodes that enable the polarity of the stator field to be reversed.



87291-III-11

Fig. 22. Various possibilities of connecting the lights.

Table 3.

number of locomotive	address				number of locomotive	address			
	A1	A2	A3	A4		A1	A2	A3	A4
01	1	0	0	0	41	X	1	1	1
02	X	0	0	0	42	0	X	1	1
03	0	1	0	0	43	1	X	1	1
04	1	1	0	0	44	X	X	1	1
05	X	1	0	0	45	0	0	X	1
06	0	X	0	0	46	1	0	X	1
07	1	X	0	0	47	X	0	X	1
08	X	X	0	0	48	0	1	X	1
09	0	0	1	0	49	1	1	X	1
10	1	0	1	0	50	X	1	X	1
11	X	0	1	0	51	0	X	X	1
12	0	1	1	0	52	1	X	X	1
13	1	1	1	0	53	X	X	X	1
14	X	1	1	0	54	0	0	0	X
15	0	X	1	0	55	1	0	0	X
16	1	X	1	0	56	X	0	0	X
17	X	X	1	0	57	0	1	0	X
18	0	0	X	0	58	1	1	0	X
19	1	0	X	0	59	1	0	X	X
20	X	0	X	0	60	0	X	0	X
21	0	1	X	0	61	1	X	0	X
22	1	1	X	0	62	X	X	0	X
23	X	1	X	0	63	0	0	1	X
24	0	X	X	0	64	1	0	1	X
25	1	X	X	0	85	X	0	1	X
26	X	X	X	0	66	0	1	1	X
27	0	0	0	1	67	1	1	1	X
28	1	0	0	1	68	reserved			
29	X	0	0	1	69	0	X	1	X
30	0	1	0	1	70	1	X	1	X
31	1	1	0	1	71	X	X	1	X
32	X	1	0	1	72	0	0	X	X
33	0	X	0	1	73	1	0	X	X
34	1	X	0	1	74	X	0	X	X
35	X	X	0	1	75	0	1	X	X
36	0	0	1	1	76	1	1	X	X
37	1	0	1	1	77	X	1	X	X
38	X	0	1	1	78	0	X	X	X
39	0	1	1	1	79	1	X	X	X
40	1	1	1	1	80	0	0	0	0

that is normally the case anyway. The above explanations should ensure that the conversion of d.c. motors for use on a Marklin system should not present any problems. Note, however, that the locomotive must be provided with a sliding contact.

Connecting the decoder and two-rail adaptor to d.c. locomotives for two-rail systems should not present any difficulties. The B(rown) and R(ed) terminals may be connected to the wheel contacts at will, since the decoder is not polarity-conscious.

## Testing and faultfinding

It is advisable to test the decoder in association with the locomotive before installing it. In the following it is assumed that at least a Marklin digital HO system is available, that is, one Central Unit, one Control 80, and one 16-V mains transformer. Later in the series, this may also be the Elektor Electronics Digital Model Train System (EDiTS).

Connect the brown and red wires of the HO system to the B and R terminals respectively on the decoder. Provided that the address keyed in on Control 80 corresponds to the address set on the

decoder, the locomotive should react to an adjustment of the speed regulator. If it does not, check that the locomotive address has been set correctly (Table 3) and that the supply for the logic circuits is 4.5—5.5 V.

If these are correct, make sure that pin 12 of IC<sub>2</sub> is logic 0 and that the oscillator operates (this is indicated by the logic level at pin 1 of IC<sub>2</sub> changing every second).

If all these are in order, measure the average output voltage at pin 1 of IC<sub>3</sub>: it should be possible to vary this with the Control 80 speed regulator between 0 V and just below the level of the supply voltage to the logic circuits. If this is not possible, check whether the logic level at pin 5 of IC<sub>3</sub> changes when the function key on Control 80 is operated.

If all these are correct, the fault lies in IC<sub>1</sub> (incorrect address or baud rate).

If the voltage at pin 1 of IC<sub>3</sub> can be varied, but the locomotive does not move, check whether pin 2 of IC<sub>3</sub> is logic 0 and pin 7 of IC<sub>3</sub> is logic 1 (or the other way round, depending on the position of the function key). If this is in order, the fault lies in IC<sub>3</sub>, or the motor is connected incorrectly, or the motor is (mechanically) impeded.

In this context, note that the outputs of IC<sub>3</sub> are not short-circuit proof: care should, therefore, be taken when lights and motor are connected. Thermal-overload protection is provided.

If the decoder operates correctly, but the last received data are lost rapidly (in spite of the external buffer capacitor) when the supply is switched off (emergency control), too high a current to the logic circuits is indicated. A possible cause of this is a short-circuit between two logic outputs or between such an output and a supply line (check the non-used outputs of IC<sub>2</sub> as well), or a zener diode with a very high leakage current. Note that solder flux is electrically conductive and may, therefore, be responsible for a short-circuit. Another possible cause of too high a current may lie in the particular type of 4060 chip. Although in all makes the outputs are reset, in some of them the internal oscillator is not switched off.

## Installation

It is advisable to glue (two-component epoxy resin or super glue) a small rectangular piece of aluminium across the decoder (IC-IC<sub>3</sub> side): this will act as a heat sink for IC<sub>3</sub>. This circuit can get pretty hot during driving, but that is normal. As long as you can put your finger to it without getting burnt, nothing untoward is happening. It cannot be too strongly emphasized to take care that there is no short-circuit between the decoder and the locomotive chassis.

The use of an external buffer capacitor

depends on the circumstances. It is essential when tracks with conventional block protection are used, that is, those that stop the locomotive by removing the voltage from the rails.

If the locomotive is stopped by switching the rails to a lower voltage (say, 8 V), an external buffer capacitor is not required. Although the charging current of the buffer capacitor is some 200 times higher than its discharge current, it may take a short time after the power is applied to the track before the decoders are ready for operation. This time lag depends on the capacitance of the buffer, and it is, therefore, not advisable to take too large a value for this component — some thousands of microfarads is quite sufficient.

## Sidings and passing loops

A classical problem with two-rail tracks is the short-circuit between the two rails when a passing loop is used. In a conventional system, the loop is electrically insulated. The locomotive moves on to the loop and while it is there the polarity of the rail voltage is changed over. Unfortunately, this also affects the direction of travel of all other locomotives on the track.

The digital system obviates this problem. The loop is again electrically insulated from the remainder of the track. The locomotive moves onto the loop as before, but in this case the polarity of the voltage on the loop is reversed while the locomotive is on the loop. This will not affect the direction of travel, because that is, after all, determined internally and independently of the polarity of the connections.

## Operational hints

As discussed in Part 2, if the decoder is used in conjunction with the Marklin digital HO system, the function switch on Control 80 changes the direction of travel. One Control 80 suffices to control a number of locomotives, but as soon as a change-over from one locomotive address to another takes place, a problem arises. The function of the newly addressed locomotive will be set automatically to 'off'. If this locomotive was previously set to 'reverse', it will suddenly change direction. This is prevented by keying in only the first digit of the new address on Control 80, then pressing the function switch (only if the relevant locomotive is set to 'reverse', of course), setting the speed controller to the position it was when the locomotive to be addressed was last controlled, and only then keying in the second digit of the address.

## Decoder modification

When the design of the decoder was started just about a year ago, availability of the MC145029 chip was assured by Motorola Europe. In spite of that assurance, production of the device was stopped in December 1988. Many constructors will, therefore, find it next to impossible to obtain the chip. For that reason, a modification was designed that is based on the MC145027 (which is also used in the points/signals decoder — see Part I — and is, incidentally somewhat cheaper than the MC145029).

In the MC145027, the first five bits are address bits and the other four are data bits, while in the locomotive decoder four address bits and five data bits are required. There is thus a shortage of one data bit: the bit that ensures changeover of direction of travel.

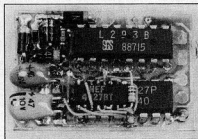

Fig. 24. The decoder board modified to operate with an MC145027 data decoder.

It is thus necessary to effect the change of direction of travel by another means, and this is done by adding a dual J-K bistable (physically glued on top of the MC145027 as shown in Fig. 24 and Fig. 27). This modification makes the change-over of direction of travel compatible with the Marklin system — see Fig. 25.

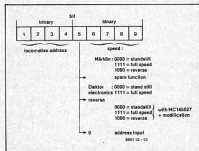

Fig. 25. The modification restores the change of direction of travel to the original Marklin concept.

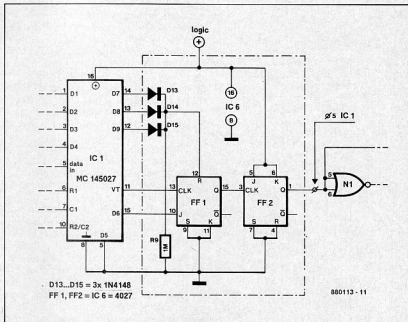

Fig. 26. Circuit diagram of the modification.

The lowest speed-step is decoded and used to clock the switching bistable. This is achieved as shown in Fig. 26.

The unused bistable in the SMT 4027, FF<sub>1</sub>, is used for decoding the lowest speed-step. It is set when its input is 1000 after which it clocks FF<sub>2</sub>. Since the J and K inputs of FF<sub>2</sub> are strapped together, the logic level of the output of the bistable changes with every clock pulse. It is thus not possible to change the direction of travel two times in quick succession, but that does not occur in practice very often in any case. If, therefore, the direction of travel was changed erroneously, this can only be corrected after FF<sub>1</sub> has been reset and this does not happen until D<sub>r</sub>, D<sub>s</sub> or D<sub>y</sub>

has become logic 1, that is, until the locomotive has travelled a short distance.

The construction of the modification requires dexterity. The pins of the MC145027, like those of the MC145029, are cut short, but pin 5 is bent away from the body slightly to enable it being soldered to the earth track adjacent to the IC<sub>1</sub> position.

As stated, glue the SMT 4027 on top of the MC145027 in such a way that pins 1 and 16 of the two ICs coincide.

The anodes of diodes D<sub>13</sub>, D<sub>14</sub> and D<sub>15</sub> are bent at right angles, cut short and soldered to pins 14, 13 and 12 respectively of IC<sub>1</sub>.

The remainder of the wiring is seen in Fig. 27. Use very thin wire (for instance enamelled copper wire or wire with teflon insulation). The output of FF<sub>2</sub> (pin 1) is connected to where originally pin 5 of IC<sub>1</sub> was connected.

Since pin 5 of the MC145027 is an address input, it is, in principle, possible to control even more than 80 locomotives as originally envisaged. If this pin is connected to the logic + line, the appropriate decoder may be accessed by keying in the locomotive address and pressing the function key. It is possible in this way to control up to 160 locomotives simultaneously.

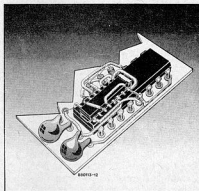

Fig. 27. Adding three diodes and a dual bistable on to the MC145027 requires some dexterity.

Parts required for modification  
 R9 = 1MΩ (physically as small as possible)  
 D13, D14, D15 = 1N4148  
 IC1 = MC145027 (in place of MC145029)  
 IC6 = 4027 (SMD)

# CLASS-D AMPLIFIER

by J. Bareford

The terms digital amplifier, class-D amplifier, switched amplifier and PWM amplifier all refer to a type of amplifier that converts its input signal into a rectangular signal with variable duty factor. The

high efficiency achieved by a class-D amplifier makes it of particular interest for mobile and public address applications, where low distortion is not a prime issue. The AF power amplifier described here works from a 6 V battery, and delivers up to 5 watts. As such, it is eminent for use in, for instance, a megaphone.

A well-known problem with mobile AF amplifiers is that their low efficiency makes it virtually impossible to generate high power levels from a low supply voltage. The amplifier described here has a total efficiency of almost 100% at a distortion level that is tolerable with megaphones and similar P.A. equipment. The basic principle behind the design is

## Pulse-width modulation

Figure 1 shows the principle of pulse-width modulation (PWM): the input signal controls the duty factor of a rectangular signal of a much higher frequency. The on-time of the pulse is proportional to the instantaneous amplitude of the input signal. The sum of the on-time and the off-time — and, therefore the frequency — is, however, constant. Hence, a symmetrical rectangular signal (square wave) is generated in the absence of an input signal.

In order to obtain reasonable sound quality, the frequency of the rectangular wave must be at least twice as high as the highest frequency in the input signal. A simple low-pass filter may then be used for integrating the rectangular signal. The result is a signal that may be used for driving a loudspeaker. The signal conversion is apparent from the lower oscilloscope trace in Fig. 4. The upper trace displays the output signal after filtering, measured across the loudspeaker. The amplitude of the residual

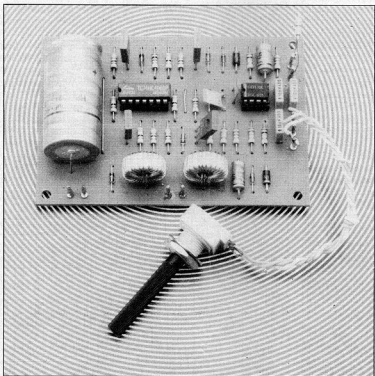

PWM signal superimposed on the sine-wave is small.

## Switches as amplifiers

The basic operation of the PWM amplifier may be illustrated with the aid of the block diagram in Fig. 2. Assuming that the input is short-circuited, switch  $S_1$  charges capacitor  $C_1$  with a current  $I_1$ , until a voltage is reached that corresponds to the upper switching threshold of the electronic switch. This then connects  $R_1$  to ground. Next,  $C_1$  is discharged to the lower switching threshold of  $S_1$ . The resulting square wave has a frequency of about 50 kHz, as determined by  $C_1$  and  $R_1$ .

An AF signal applied to the input of the

amplifier effectively causes the additional current  $I_1$  to proportionally reduce or increase the charge time, and increase or reduce the discharge time. The input signal thus controls (*modulates*) the duty factor of the rectangular signal which appears at the loudspeaker output.

Two further principles are important for the basic operation of the PWM amplifier. First, switch  $S_2$  is controlled in anti-phase with  $S_1$ , and keeps the other loudspeaker terminal at a voltage complementary to that of the PWM signal. This arrangement results in a switching power output stage of the bridge type: the loudspeaker is driven with the full supply voltage at each polarity, so that the highest possible current consumption is achieved.

The second additional point to note concerns inductors  $L_1$  and  $L_2$ . These integrate the rectangular signal and so make it sinusoidal as seen in Fig. 4. The inductors also serve to suppress harmonics of the 50 kHz rectangular signal.

## High sound levels from a small circuit

The components shown in the block diagram are easily recognized in the circuit diagram of Fig. 3. The input section of the PWM amplifier is formed by a capacitor (or electrostatic) microphone, biased via  $R_1$ , coupling capacitors  $C_1$  and  $C_4$ , a volume control,  $P_1$ , and an

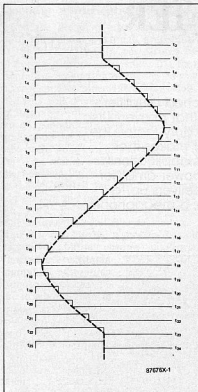

Fig. 1. Conversion of a sine-wave into a pulse-width modulated (PWM) signal.

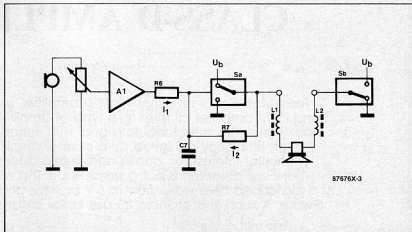

Fig. 2. Block diagram of the class-D amplifier.

amplifier based around opamp A1. The previously discussed switches S<sub>1</sub> and S<sub>2</sub> are formed by electronic switches ES<sub>1</sub> to ES<sub>4</sub> in combination with transistor pairs T<sub>1</sub>-T<sub>3</sub> and T<sub>2</sub>-T<sub>4</sub>. The part indications for the components that form the PWM generator correspond to those discussed with the block diagram.

The unusually high efficiency of the PWM amplifier is perhaps best illustrated by the fact that the output transistors remain cool under all drive con-

ditions — dissipation in the power output stage is virtually nought.

When selecting practical inductors for L<sub>1</sub> and L<sub>2</sub>, remember that their ability to pass 3 A without becoming saturated is far more important than the actual inductance. The inductors used in the prototype were toroid types salvaged from a lamp dimmer.

Diodes D<sub>3</sub> to D<sub>6</sub> limit the reverse e.m.f. generated by the inductors to a safe

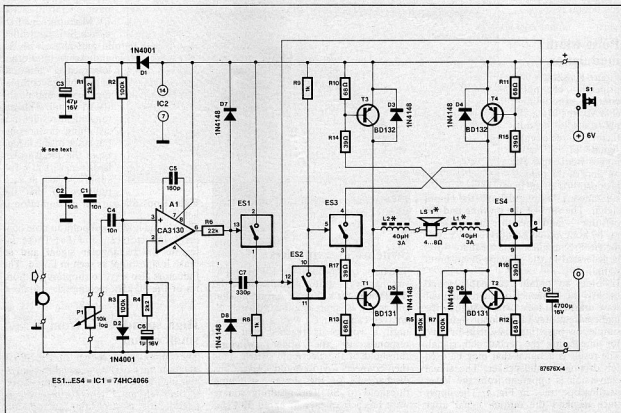

Fig. 3. Circuit diagram of the 4 W class-D amplifier for public address applications.

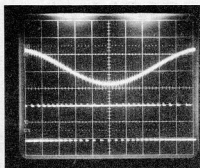

Fig. 4. Sinusoidal output signal (upper trace) and PWM control signal (lower trace).

value. Components  $D_1$ ,  $C_3$ ,  $D_2$  and  $R_3$  provide the non-inverting input of opamp  $A_1$  with a well-filtered potential equal to half the supply voltage. As with a conventional opamp-based amplifier, the voltage gain is set by a negative feedback network. In practice,  $R_4$  and  $R_5$  set

the gain to 83 to ensure adequate microphone sensitivity. When high-impedance signal sources are used,  $R_4$  may be increased accordingly.

Because of the phase shift introduced by  $L_1$  and  $L_2$ , feedback is realized with the aid of the rectangular signal at the collector of  $T_1$ , rather than with the sinusoidal loudspeaker signal. The opamp itself, in combination with  $C_5$ , provides the required integration of the PWM feedback signal. It should be noted that the feedback system reduces the amplifier's distortion, but not, unfortunately, to a level that would make it suitable for applications other than public address. A class-D amplifier with low distortion would require a much higher supply voltage than used here, and would be a fairly complex design. This, in turn, would almost inevitably result in much reduced overall efficiency. The electronic switches in the amplifier must be HCMOS types — a standard CMOS Type 4066 is so slow as to cause

a short-circuit across  $T_1$ - $T_3$  and  $T_2$ - $T_4$ , with the obvious risk of overloading or even destroying the amplifier.

## Bullhorn

The class-D amplifier is preferably used for driving horn-type loudspeakers, since these offer the highest sound pressure for a given power level. The prototype of the amplifier was used in combination with a 6 V battery pack and a pressure chamber loudspeaker. The available 4 watts of output power resulted in a megaphone with an impressive acoustic range.

Four series-connected 1.5 V dry batteries (HP11; C; UM2; Baby) or alkaline monocells provide the supply voltage for the megaphone. When this is used frequently, a rechargeable NiCd or gel-type (Dryfit) battery may be preferred. The maximum current consumption of the megaphone is about 0.7 A, so that an alkaline battery has sufficient capacity for 24 hours operation at full output power. For non-continuous operation, however, a set of dry batteries is perfectly adequate.

Whatever power source is used, the supply voltage for the amplifier should not exceed 7 V, because the HCMOS switches in  $IC_2$  do not operate correctly any more at this level. Fortunately, the absolute maximum supply level for the amplifier is higher at 11 V.

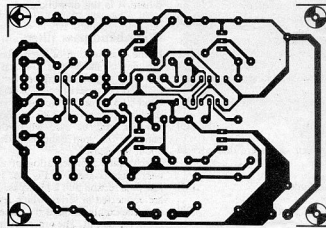
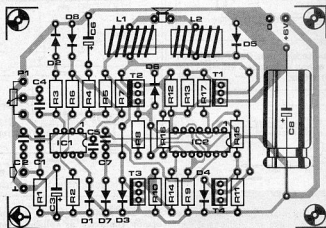

Fig. 5. Printed-circuit board for the amplifier.

### Parts list

#### Resistors ( $\pm 5\%$ ):

- $R_1, R_4 = 2K2$
- $R_2, R_3, R_7 = 100K$
- $R_5 = 180K$
- $R_6 = 22K$
- $R_8, R_9 = 1K0$
- $R_{10} \dots R_{13}$  incl. = 68R
- $R_{14} \dots R_{17}$  incl. = 39R
- $P_1 = 10K$  logarithmic potentiometer

#### Capacitors:

- $C_1, C_2, C_4 = 10n$
- $C_3 = 47\mu$ ; 16 V
- $C_5 = 180p$
- $C_6 = 1\mu$ ; 16 V
- $C_7 = 330p$
- $C_8 = 4700\mu$ ; 16 V

#### Semiconductors:

- $D_1, D_2 = 1N4001$
- $D_3 \dots D_4$  incl. = 1N4148
- $T_1, T_2 = BD131$  or  $BD226$
- $T_3, T_4 = BD132$  or  $BD227$
- $IC_1 = CA3130$
- $IC_2 = 74HC4066$

#### Miscellaneous:

- $S_1 =$  push-to-talk switch.
- $L_1, L_2 = 40\mu$ ; 3 A toroid suppressor choke.
- $LS_1 = 4 \dots 8R$ ; 10 W; waterproof horn loudspeaker.
- Capacitor microphone.
- PCB Type 87676



# PRACTICAL FILTER DESIGN (4)

by H. Baggott

The previous part in this series discussed the most important low-pass filters. This month we turn our attention to high-pass and band-pass networks. Since these are derived from low-pass sections, we often speak of derived filters.

A high-pass section is derived simply from a low-pass section by substituting  $1/j\omega$  in the transfer function for  $j\omega$ . This is not nearly as complicated as it looks, and is fairly easily realized in practical terms as well. In practice, it means that in a passive filter all inductances are replaced by capacitances and all capacitances by inductances. In an active filter, all resistances and capacitances are interchanged.

The computation of the new components is also simplicity itself. First, calculate the normalized values of all components for the low-pass section, replace the components by their "opposites" and compute the values of the newly required components as follows.

Passive filters:

$$CHP = 1/LPL$$

$$LHP = 1/CLP$$

Active filters:

$$CHP = 1/RLP$$

$$RHP = 1/CLP$$

Once the normalized high-pass filter has been computed in this way, the actual component values are dimensioned for the required cut-off frequencies.

Figures 18, 19, 20, 21, 22 and 23 show the high-pass filters derived from the low-pass sections discussed in Part 3. These are:

- passive type with equal input and output impedances;
- passive type connected to source of negligible internal resistance;
- two-pole active type with voltage follower;
- a filter with a real pole;
- a two-pole filter with variable gain;
- a state-variable filter.

The interchanging of resistances and capacitances does not work in a state-variable filter. This type requires the addition of a summing amplifier that combines the input signal, the band-pass signal and the low-pass signal into a

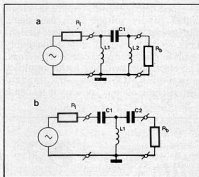

Fig. 18. Passive high-pass filters with equal input and output impedances ( $R_1=R_2$ ): (a) m-type; (b) T-type.

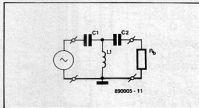

Fig. 19. Passive high-pass filter connected to a source of negligible resistance and terminated in  $R_1$ .

high-pass function. In the case of an odd-order filter, the amplifier is followed by a passive RC filter.

The computation of the various components in a state-variable high-pass filter is carried out as follows. First, calculate the normalized high-pass pair of poles:

$$\alpha' = \alpha / (\alpha^2 + \beta^2) \quad [25]$$

$$\beta' = \beta / (\alpha^2 + \beta^2) \quad [26]$$

The component values are then arrived at:

$$R_1 = R_2 = 1 / (4\pi\alpha'C) \quad [27]$$

$$R_3 = R_4 = 1 / 2\pi C \sqrt{[(\alpha')^2 + (\beta')^2]} \quad [28]$$

$$R_5 = 2\alpha'R / \sqrt{[(\alpha')^2 + (\beta')^2]} \quad [29]$$

$$R_6 = AR \quad [30]$$

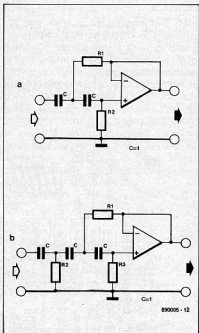

Fig. 20. Active high-pass sections with opamp connected as voltage follower: (a) two-pole type and (b) three-pole type.

where  $A$  is the amplification.

## Wide band-pass filters

In the computation of band-pass filters use may be made of a low-pass and a high-pass section that, dependent on the required characteristics — band-pass or band-stop — are connected in series or parallel respectively. This method can, however, only be used where the pass band or the stop band is wider than about an octave.

A schematic representation of a band-pass filter is given in Fig. 24. Here, a low-pass section and a high-pass section are connected in series, which results in only the common band ( $f_1-f_2$ ) appearing at the output. The order in which the two are connected is not important as long as the low-pass cut-off frequency,  $f_1$ , is higher than that of the high-pass

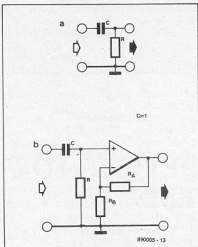

Fig. 21. A real pole is provided by a simple RC network (a). The addition of an opamp (b) enables buffering and amplification.

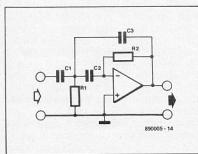

Fig. 22. A two-pole active high-pass section with variable gain.

section,  $f_1$ .

A schematic representation of a band-stop filter is shown in Fig. 25. Here, a low-pass section and a high-pass section are connected in parallel to prevent the band  $f_1$ — $f_2$  appearing at the output. The major difference between the filter in Fig. 24 and that in Fig. 25 is the fact that in the former the low-pass cut-off frequency is higher than the high-pass cut-off frequency, while in the latter it is the other way around.

The sections are computed in the usual way as discussed, after which they are combined. Both the band-pass and the band-stop filter may be passive or active. In a passive type the input and output impedances must be equal, otherwise there will be a mismatch that will adversely affect the filter characteristic. In the case of an active filter, the two sections are connected in cascade to form a band-pass filter, and in parallel with the aid of an additional summing amplifier to form a band-stop filter.

Next month's instalment will deal with narrow band-pass filters.

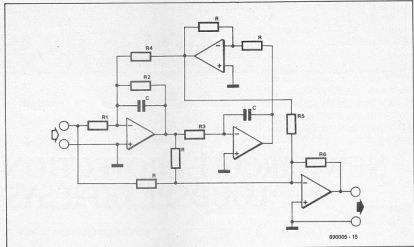

Fig. 23. A state-variable high-pass filter needs an extra opamp.

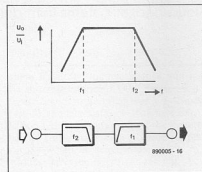

Fig. 24. A wide band-pass filter is obtained by connecting a low-pass section and a high-pass section in series.

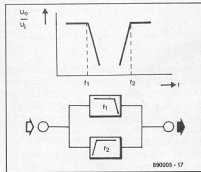
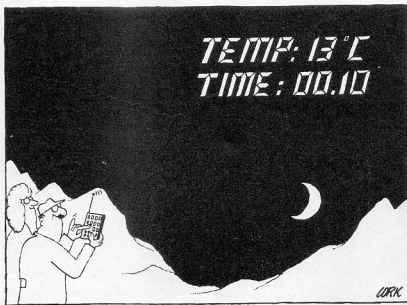

Fig. 25. A wide band-stop filter is obtained by connecting a low-pass section and a high-pass section in parallel.



## NEW CIRCUIT PROTECTION DEVICES FOR LOUDSPEAKER SYSTEMS

by Derek Overton\*

A novel type of circuit-protection device is now available to protect loudspeaker systems from damage.

Loudspeakers are generally designed and sold separately from amplifiers. Thus, mismatches may occur that can lead to damage. It should be noted that modern digital recordings often place additional burdens on an audio system.

Speaker damage may result from a number of factors, including the following.

- High-power amplifiers may simply overdrive the speech coils with excessive power on sustained programme material.
- Digital recordings, with their ability to reproduce high-frequency sound, place an extra strain on tweeters.
- Low-power amplifiers may be operated in clipping mode, which causes an upward frequency shift of power into the tweeter, resulting in an overload. This problem is especially common with the wide dynamic range of digitally programmed material.
- Unstable amplifier systems may oscillate in the ultrasonic range, which overloads the tweeter.

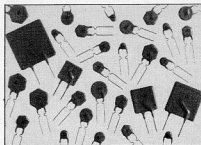

Fig. 1. A selection of Bourns MultiFuse™ resettable PTC circuit-protection devices.

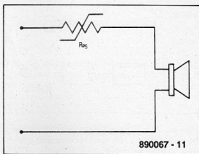

Fig. 2. A PTC device in a typical circuit.

A new range of Positive-Temperature-Coefficient (PTC) circuit-protection devices is now available to overcome these problems.

The new devices, known as MultiFuse™, act like fuses under overcurrent conditions, but "reset" themselves by returning to their low-resistance state once they cool below their "trip" temperature.

Because of this, they overcome the drawbacks of other overcurrent protection products such as fuse links, bimetallic circuit breakers or ceramic temperature-dependent resistors. Fuse links are not resettable; bimetallic circuit breakers are prone to vibration, welding, sparking, contact-resistance variation and recycling problems; and ceramic devices are slow in operation and may suffer from low-resistance or short-circuit problems under certain conditions.

Under normal conditions, the resistance of a MultiFuse™ device is comparable to that of a fuse link — between milliohms and a few ohms — depending

on the specified current-carrying capacity. When an overcurrent heats it up to its trip temperature, its resistance increases by many orders of magnitude, limiting the current from the power source and thereby protecting the circuit.

Once tripping has occurred, the residual current maintains the device above its trip temperature, and latches it in its protective high-resistance state. The device will return to its low-resistance state and reset once it cools below its trip temperature, which is achieved by switching the power off or substantially reducing the current. Once the fault condition has been cleared and the device reset, normal circuit operation resumes.

With a MultiFuse™ circuit protection device in series with a loudspeaker (either before or after the cross-over filter), a sustained overload causes the device to switch to a high-resistance state to protect the loudspeaker. A reduction in drive power, resulting either from a change in the music or by the user turning down the power, allows the device to reset automatically.

A properly sized device can be put in series with the loudspeaker to be protected as shown in Fig. 2. The device has a low resistance (typically 0.030-0.2  $\Omega$  for common loudspeaker sizes) and essentially no impedance.

Thus, the only effect on sound is a slight reduction in drive power (typically less than 0.1 dB). No measurable distortion has been found with normal signal levels.

A sustained overdrive condition causes the device to switch to high resistance. The speed of tripping depends on the amount of overcurrent. The resistance level in the tripped state (RPS) depends

\* The author is with Bourns Electronics Limited

on the power dissipation of the device (PD, which is essentially a constant) and the square of the drive voltage,  $V$ , specifically:

$$R_{PS} \approx V^2 / PD$$

Therefore, once a device trips, an increase in drive voltage raises, and a decrease lowers, the resistance of the device. The increased resistance is typically thirty to forty times higher than the base resistance, and this causes an abrupt reduction in power to the loudspeaker when the device trips.

The effect on load power is illustrated in Fig. 3. Initially, load power increases with drive voltage. When the drive voltage causes an excess current to trip the device, load power is reduced typically by 20-30 dB. Further increases in drive voltage reduce the load power even more.

A reduction in drive voltage increases the power to the load. Since the device is now the dominant load, it does not trace back the original curve. Rather, the drive voltage must be reduced until the device can no longer draw the power (typically 2-3 W) to maintain itself in the tripped state. The approximate condition for the device to untrip is:

$$V^2 / 4R_L \leq PD$$

where  $R_L$  is the load resistance. The untripping is visible on the decreasing drive-voltage portion of Fig. 3.

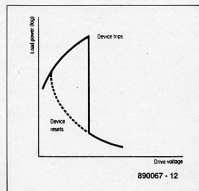

Fig. 3. Effect on load power.

Once the device has reset, normal operation is restored. Since the device has a somewhat higher resistance immediately after resetting, subsequent trips will occur at lower power during that period. If the user keeps the power down to obviate subsequent trips, the resistance relaxes and the component eventually resumes its initial value.

## Shunt resistance

Some users may like to reduce drive power by a known, fixed amount in the

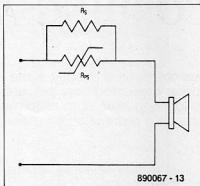

Fig. 4. PTC device with shunt resistor.

case of a fault, rather than the large variable amount provided by a MultiFuse™ device. Shunting the device with a fixed resistance as in Fig. 4 generates a fixed reduction if the device trips. The amount of reduction depends on the resistance used. The reduction in decibels is roughly

$$20 \log [R_L / (R_L + R_S)]$$

where  $R_L$  is the load resistance and  $R_S$  the shunt resistance.

Figure 5 shows the effects of a 5 Ω and a 10 Ω shunt resistance with a 1.85 A device. Until tripping occurs, the system follows the same curve as before (upper trace). When it trips, the device introduces an essentially fixed resistance in series with the load. This action reduces the output by a fixed amount. Now, the load power rises with increasing drive and diminishes with decreasing drive. The resistor must be rated to dissipate the power it would if the device were not in circuit.

In much the same way, a light bulb (typically an automotive bulb) can be connected in parallel with a MultiFuse™ device as shown in Fig. 6. Normally, the device carries by far the larger part of the current because its resistance will be less than one-fifth of that of the bulb.

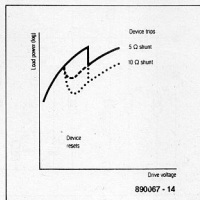

Fig. 5. Response of PTC device with shunt resistor.

When the device trips, most of the current flows through the bulb (which is also a PTC component). This introduces additional resistance into the circuit and limits the power. As with a fixed resistance, increases in drive voltage cause a rise in load power. However, owing to the variable PTC characteristic of the bulb (a resistance change of roughly 1:10 is available), that increase is less than proportional. As the drive power is reduced, the two PTC components go through a complex balancing act until the MultiFuse™ resets.

## Design considerations

The decision as to which MultiFuse™ to use must be based on a knowledge of the specific protection needs of the loudspeaker under design. An analysis of the

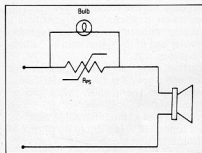

Fig. 6. PTC device with shunt light bulb.

time it takes to cause damage at various drive currents is very useful in understanding the protection needs of the driver. If this information is not available, an estimate of the maximum safe current can help. The amount of series resistance that can be added is also an important consideration. The data sheets for the MultiFuse™ devices show the minimum and maximum time-to-trip curves (normalized to I<sub>HOLD</sub>). If the designer has access to time-to-damage information for the driver, a comparison with the device's time-to-trip curves will indicate the part to try. If a complete time-to-damage curve is not available, the designer may choose a part with a current rating (I<sub>TRIP</sub>) just below the maximum safe current. In either case, the designer should conduct an empirical investigation to verify performance.

When carrying out such a study, the designer has to keep in mind that the longest time for a circuit device to trip is when it is new or has not been tripped for a long period. Therefore, the protection action of a device should be tested with fresh devices. On the other hand, the shortest time to trip occurs when the device has just tripped and the maximum normal operational conditions (current and temperature) therefore need to be tested with devices that have recently tripped.

# VIDEO RECORDING AMPLIFIER

When video tapes are copied directly, some loss of quality is inevitable. The amplifier presented here prevents this deterioration and also provides four separate outputs to make it suitable for use as a distribution amplifier.

One criterion in the judging of the quality of a video recording is the resolution or definition, that is, picture clearness, which is related directly to the bandwidth the video recorder can handle. During re-recording, some deterioration of picture quality occurs because the bandwidth is reduced to a degree that depends on the recording system. This reduction manifests itself primarily in a greater attenuation at the high-frequency end of the signal than at the low-frequency end.

Further loss of quality may occur through a lowering of the overall modulation level, particularly when two or more video recorders, or a video recorder and a colour television monitor, are connected in tandem to the output of the master television receiver or recorder. It would be possible to simply increase the gain of the slave equipment. Unfortunately, maximum frequency-selective amplification and optimum quality can not be achieved by simple means. There would, for instance, be a danger of over-modulation, which would result in a deterioration, rather than an enhancement, of the signal.

The present amplifier provides separate level and modulation (contour) controls, and four independent outputs to enable the simultaneous feeding of up to four video recorders.

## Circuit description

Field-effect transistors T1 and T2 in Fig. 1 form a differential amplifier that offers high input impedance, small phase shift and excellent bandwidth. The output of the master television receiver or video recorder is applied to the gate of T1 via C1. Resistors R3 and R5, and capacitor C2, serve to determine the d.c. operating point.

The output of T1 is amplified in T3 and push-pull amplifier T4-T5, and then fed back to T2 via R13. The value of R8 ensures that the overall gain is not less than 6 dB.

The feedback (and the carefully designed printed-circuit board) ensures excellent stability in conjunction with good phase behaviour, ample bandwidth, and adequate gain.

Setting of the quiescent current through the output stages is provided automati-

cally by low-capacitance diodes D1-D3 and emitter resistors R16 and R17.

The highly stable video signal is fed to the four outputs via low-reactance electrolytic capacitor C6 and resistors R19-R22.

The AV input of video recorders and monitors is generally terminated by a 68-82  $\Omega$  (nominally 75  $\Omega$ ), so that connection to the present amplifier results in a 6 dB attenuation of the signal. Since the recording amplifier has a gain of not less than 6 dB, the level of the effective input to equipment connected to its outputs is at least equal to that of its own input.

Level-control potentiometer R10 affords additional amplification of the output signal, which is particularly useful if all four outputs are loaded.

Envelope (contour) control R12 enables extra amplification of the high-frequency part of the signal.

The required bandwidth of 50 Hz to 5 MHz is exceeded by a large margin: the power bandwidth of the prototypes stretched from 20 Hz to 25 MHz.

Power requirement of the amplifier is 10-15 V (nominally 12 V) at 50 mA.

The power lines are decoupled by R1 and C7.

Some video recorders have a 12 V output that is ideal for the present amplifier. It is, however, advisable to consult the recorder handbook to make sure that this output can deliver up to 50 mA.

## Construction

It is strongly recommended to construct the amplifier on the ready-made printed-circuit board, since the design of this makes a substantial contribution to the proper operation of the amplifier.

The two potentiometers (R10 and R12) should be mounted on soldering pins (3 each).

Note that points a-i in Fig. 1 correspond to the identically marked ones on the PCB (Fig. 2).

As there is quite a variety of relevant plugs and sockets used in video equipment, the parts list intentionally does not state any particular make. It is best to buy a video recording cable specially made for the relevant VCR together with the matching plug or socket (which is then fitted on to the present amplifier).

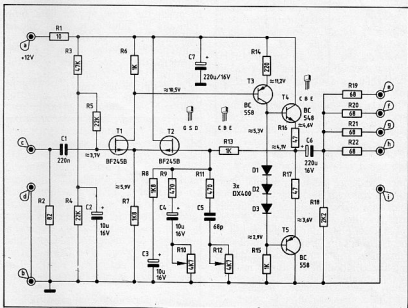

Fig. 1. Circuit diagram of video recording amplifier.

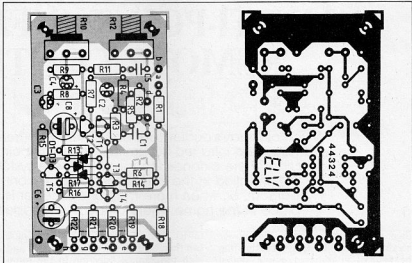
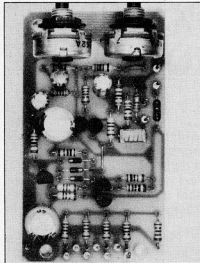

Fig 2. Printed-circuit board for the video recording amplifier.

#### Parts list

##### Resistors:

- R1 = 10R
- R2 = 82R
- R3 = 47k
- R4;R5 = 22k
- R6;R13;R15 = 1k
- R7;R8 = 1k8
- R9;R11 = 470R
- R10;R12 = 4k7 linear potentiometer; 4 mm spindle
- R14 = 220R
- R16;R17 = 47R
- R18 = 2k2
- R19—R22 = 68R

##### Capacitors:

- C1 = 220n
- C2—C4 = 10 $\mu$ F; 16 V
- C5 = 68p
- C6;C7 = 220 $\mu$ F; 16 V

##### Semiconductors:

- T1;T2 = BF245B
- T3;T5 = BC558
- T4 = BC548
- D1—D3 = DX400

##### Miscellaneous:

- 9 soldering pins
- 2 push-on knobs, 10 mm  $\varnothing$  with indicator

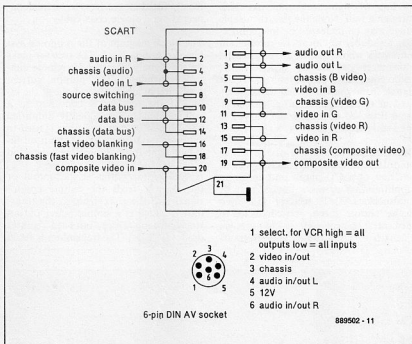

Fig. 3. Pin-out of the most popular sockets found on television receivers and video recorders.

The audio signals at the master television receiver or video recorder output are connected directly to the slave VCR(s) as the present amplifier does not cater for these signals. This is done because there is hardly any attenuation of the audio signals, since the audio inputs on VCRs are always terminated into a high impedance.

# MULTI-POINT INFRA-RED REMOTE CONTROL

by T. Giffard

Much of today's audiovisual equipment is remote-controlled from a handheld infra-red transmitter. The multi-point control system described here extends the range of these systems, so that, say, a VCR installed in the living room can be controlled from the bedroom, or, when more than one receiver is used, from any place in the home where a 'local IR feedpoint' is installed.

There is little point in using high-power infra-red emitter devices for extending the range of an IR-based remote control for audiovisual equipment in the home, simply because an infra-red beam travels by line of sight, and can not pass through a wall. None the less, the usable range may be increased by interconnecting a number of 'local' IR receivers in a network whose output drives a central transmitter pointed at VCR, TV or audio equipment. In this manner, the IR signal from one or more transmitters used at some distance from the equipment is picked up locally and relayed to the central control.

One example of the use of the multi-point IR remote control concerns a combination of a CD player and an audio amplifier that drives a remote pair of loudspeakers. An IR receiver is installed in the 'remote' room, and connected to the central control in the living room via a length of coax cable. The IR trans-

mitter that 'belongs to' the audio rack can then be used for volume control and even programme selection in the room with the extra pair of loudspeakers. As already stated, the system allows several locally fitted IR receivers to be interconnected via a single coax cable.

The block diagram of the proposed system is given in Fig. 1. The receiver picks up the signals from the IR remote control transmitter. The photon current generated in an IR photodiode at the input of the receiver is converted to a voltage that is subsequently amplified and filtered. A double T-filter is used to suppress modulated 100 Hz hum on incident light from fluorescent tubes and other light sources.

A comparator/buffer at the output of the receiver feeds the remote control signal into the coax cable to the transmitter, which is a simple power output stage driving three infra-red emitter diodes (IREDs). The transmitter is fitted

at a point within the normal reach of the receiver that forms part of the audio or audiovisual equipment.

## Practical circuit

The circuit diagram in Fig. 2a shows that the photodiode, a BP104, is connected to the inverting input of current-to-voltage (I-V) converting opamp IC<sub>1</sub> via a coupling capacitor, C<sub>2</sub>. The capacitor prevents slow changes in the ambient light intensity being passed to the opamp. The photodiode is reverse-biased by decoupled series network R<sub>1</sub>-R<sub>2</sub>. This is done to reduce the parasitic capacitance in the off-state of the photodiode, and thereby ensure a short pulse response time. Since the receiver is a single-supply design, the non-inverting input of IC<sub>1</sub> is held at half the supply voltage with the aid of potential divider R<sub>3</sub>-R<sub>4</sub>.

The amplified voltage at the output of the I-V converter is applied to a double T-filter, R<sub>5</sub> through R<sub>9</sub> and C<sub>3</sub> through C<sub>5</sub>, dimensioned for 100 Hz. The filter has no effect on the pulse train received from the IR transmitter, because this signal usually has a frequency much higher than 100 Hz.

A buffer/comparator stage built around another fast opamp, IC<sub>2</sub>, restores the shape of the control pulses and drives output stage T<sub>1</sub>-T<sub>2</sub>. In this stage, T<sub>1</sub> functions as a 200 mA current source, so that the termination impedance of the coax cable is determined by R<sub>14</sub> only. The current source also prevents problems arising from the parallel connection of several receivers to the single coax cable.

The pulses at the output of IC<sub>2</sub> switch T<sub>1</sub>, which in turn switches the current source, T<sub>2</sub>, on and off.

Preset P<sub>1</sub> compensates the off-set introduced by both opamps. The adjustment of this compensation will be reverted to in detail because it is essential for correct operation of the control system.

The receiver is powered by a small mains adapter providing 12 VDC output at about 250 mA. The use of a mains

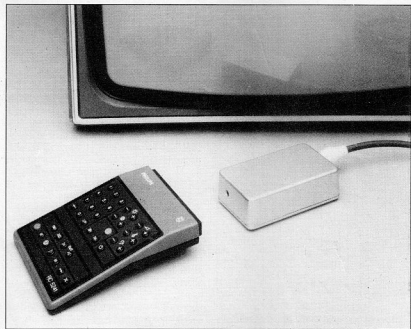

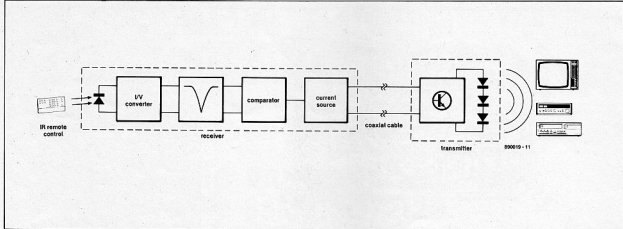

Fig. 1. Block diagram of the multipoint IR remote control system.

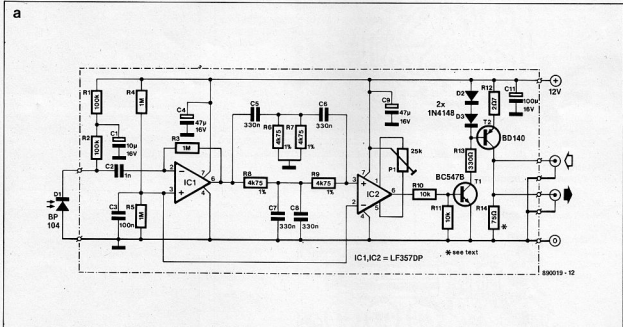

Fig. 2. Circuit diagram of the receiver (a) and transmitter (b).

power supply in the same enclosure as the IR receiver is not recommended for reasons of safety and possible interference.

The central IR transmitter (Fig. 2b) is essentially composed of a medium-power transistor, T<sub>1</sub>, and 3 series-connected IREDs fitted with small reflectors. By virtue of the current source(s) in the receiver(s), the IRED driver can be powered from a 9 V battery because it only draws current when a pulse is transmitted.

### Construction

The multi-point IR remote control system is simple to build on the printed circuit boards shown in Figs. 3 (receiver)

and 4 (transmitter). For optimum noise suppression, the completed receiver board is either screened with tin or brass plates, or mounted in a metal enclosure with holes for the supply cable, the coax cable(s) and, of course, the photodiode. The latter should remain on the PCB, i.e., it must not be connected with a cable, however short this may be.

When several receivers are connected to the coax cable, *only the one at the end of the cable* should be fitted with a 75 Ω termination resistor, R<sub>14</sub>. Each receiver is best mounted near a mains outlet, at a height of about 1 m above the floor.

The transmitter plus battery may be mounted in an ABS enclosure, which is permanently installed in the same room

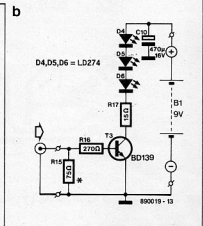

as the controlled equipment. The IREDs must, of course, be pointed towards the receiver diode in the equipment.



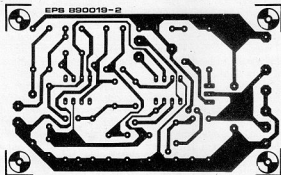
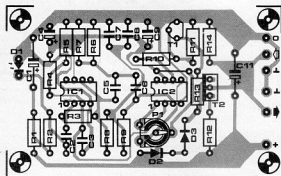

Fig. 3. Printed-circuit board for the IR receiver. Screening is essential!

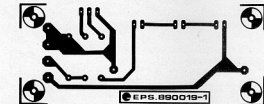
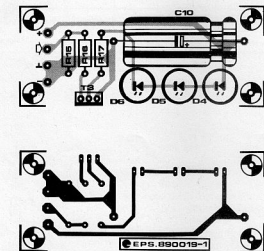

Fig. 4. Printed-circuit board for the IR transmitter.

### Setting up

Preset P1 should be adjusted with care to avoid the transmitter draining the battery in a few minutes, or R17 overheating.

5.42 *elektor india may 1989*

Disconnect the transmitter from the receiver(s). Apply power to the receiver, and connect a DC voltmeter to the output of IC2 (pin 6). Carefully adjust P1 until the output is just low when no

### Parts list

#### INFRA-RED RECEIVER:

##### Resistors ( $\pm 5\%$ ):

R1, R2 = 100K  
 R3, R4, R5 = 1M $\Omega$   
 R6...R9 incl. = 4K7 $\Omega$ ; 1%  
 R10, R11 = 10K  
 R12 = 2R7  
 R13 = 330R  
 R14 = 75R (see text)  
 P1 = 25K preset H

##### Capacitors:

C1 = 10 $\mu$ ; 16 V  
 C2 = 1n0  
 C3 = 100n  
 C4, C9 = 47 $\mu$ ; 16 V; tantalum  
 C5...C8 incl. = 330n  
 C11 = 100 $\mu$ ; 16 V

##### Semiconductors:

D1 = BP104  
 D2, D3 = 1N4148  
 IC1, IC2 = LF357DP  
 T1 = BC547B  
 T2 = BD140

##### Miscellaneous:

PCB Type 890019-1

Mains adaptor 12 VDC @ 250 mA.

### Parts list

#### INFRA-RED TRANSMITTER:

##### Resistors ( $\pm 5\%$ ):

R15 = 75R  
 R16 = 270R  
 R17 = 15R

##### Capacitor:

C10 = 470 $\mu$ ; 16 V

##### Semiconductors:

D4, D5, D6 = LD274  
 T3 = BD139

##### Miscellaneous:

PP3 9 V battery.  
 3 reflectors (for D4, D5 and D6).  
 PCB 890019-2

signal is received. If available, an oscilloscope may be used to verify the absence of oscillation signals or interference at the output. The transmitter is then connected again, and the multi-point IR control is ready for use. ■

# APPLICATION NOTES

## DYNAMIC RANGE PROCESSOR TYPE SSM2120/2122

Integrated circuit Type SSM2120 from Precision Monolithics Inc. is a dynamic range processor designed specifically for use in professional audio systems. The chip, housed in a 22-pin 'skinnydip' package, has two fully independent class A voltage controlled amplifiers (VCAs) that exhibit very low distortion and offer a 100 dB dynamic range. Each VCA has two complementary antilog (dB/volt) control ports to simplify system design. Also included on the chip are two independent control side chain circuits, each of which consists of a full-wave rectifier, a logging circuit, and a high-impedance amplifier. The log/antilog nature of the control paths makes poss-

ible precisely defined compression/expansion ratios over a 100 dB dynamic range.

The SSM2122 is the same die offered in a 16-pin package for use as a dual VCA without the level detection circuitry accessible.

### Voltage controlled amplifiers

The two VCAs in both the SSM2120 and the SSM2122 are full class A current in/current out devices with complementary dB/volt gain ports. For best performance, these pins should be connected to ground with resistors valued at 200Ω or less. Control sensitivities at the

pins are ±6 mV/dB. The resistor to ground forms part of an attenuator that determines the sensitivity of the VCA to a control voltage source.

The signal inputs are virtual grounds and the outputs are designed to be connected to the virtual grounds of operational amplifiers configured as current-to-voltage converters. The input/output current compliance range is determined by the current into the reference current pin (pin 10 for the 2120 and pin 7 for the 2122). The voltage at the pin is about two volts above the negative supply. A resistor can be connected from the pin to the positive supply with a value that determines the current into the pin. The current consumption of the device will be directly proportional to this current which should be nominally 200 μA. Smaller values can be chosen for battery operation at the expense of a lower dynamic range from the VCAs. With a 200 μA reference current, the input/output current clip point at unity gain will be ±400 μA. In the general case

$$I_{clip} = \pm 2I_{ref}$$

This, together with the power supplies used, determines the value of input and output resistors for optimum dynamic range. For example, with ±15 V supplies,

$$400 \mu A \times 36 k = 14.4 V$$

which coincides with the output clip points of the opamps.

The CFT pins are optional control feedthrough null points that are required in some applications, most notably noise gating and downward expansion. The trim procedure is to apply a sinusoidal signal at 100 Hz to the control point attenuator whereby its peaks correspond to the VCAs' maximum intended gain and at least 30 dB of attenuation. The trimpot is then adjusted for minimum feedthrough. With 36 kΩ input and output resistors, the trimmed control feedthrough is typically well under 1 mV r.m.s. This adjustment may not be re-

### PRELIMINARY SPECIFICATIONS\*

Operating Temperature: -10°C to +55°C; Storage Temperature: -55°C to +125°C

The following specifications apply for @V<sub>S</sub> = ±15V, T<sub>a</sub> = 25°C, I<sub>ref</sub> = 200 μA

PARAMETER	MIN	TYP	MAX	UNITS	CONDITIONS
<b>General</b>					
Positive Supply Range	+5		+18	V	
Negative Supply Range	-18		-5	V	
I <sub>cc</sub>		8	10	mA	
I <sub>zz</sub>		6	8	mA	
<b>VCA's</b>					
Max I <sub>load</sub> (in/out)	±387	±400	±413	μA	
Output Offset		±1	±2	μA	
Control Feedthrough (trimmed)		750		V	
Gain Control Range	-100		+40	dB	Unity Gain
Control Sensitivity		6		mV/dB	
Gain Scale Factor Drift		-3300		ppm/°C	
Frequency Response		250		kHz	Unity Gain or less
Off Isolation		100		dB	@ 1KHz
Current Gain	-0.25	0	+0.25	dB	V <sub>cc</sub> = V <sub>EE</sub> = 0V
THD (Unity Gain)		0.005	0.02	%	+10dBV In/Out
Noise (20KHz Bandwidth)		-80		dB	RE: 0dBV
<b>Level Detectors (2120 only)</b>					
Dynamic Range	100	110		dB	
Input Current Range	0.03		3000	μApp	
Rectifier Input Bias Current		4	16	mA	
Output Sensitivity		3		mV/dB	
Output Offset Voltage		±0.5	±2	mV	
<b>Frequency Response:</b>					
f <sub>IN</sub> = 1mA <sub>app</sub>		1000		KHz	
f <sub>IN</sub> = 10mA <sub>app</sub>		50		KHz	
f <sub>IN</sub> = 1mA <sub>app</sub>		7.5		KHz	
<b>Control Amplifiers (2120 only)</b>					
Input Bias Current		85	175	nA	
Output Drive (Max Sink Current)	5.0	7.5		mA	
Input Offset Voltage		±0.5	±2	mV	

\*Specifications are subject to change without notice.

quired in compressor/limiter applications because the VCA operates at unity gain unless the signal is large enough to initiate a gain reduction, in which case the control feedthrough is masked by the signal. The trim is ineffective for voltage controlled filter circuits. Typical THD and noise performance characteristics are given in Fig. 1 and Fig. 2 respectively. Leave the CFT pins open if unused.

## Control sections (2120 only)

The 2120 has two separate control sidechain circuits, each of which consists of a wide dynamic range full-wave rectifier and logging circuit followed by an amplifier with unipolar drive. The rectifier input has a d.c. voltage of about 2.1 V above ground, so that for proper operation a low-leakage blocking capacitor is required in series with the input resistor. The resistor should be chosen to give a  $\pm 1.5$  mA peak input signal. When operating from  $\pm 15$  V supplies, this corresponds to a value of 10 k $\Omega$ . The detector will provide accurate level information over a dynamic range from 3 mA to 30 nA peak-to-peak, or about 100 dB. The logarithm of this level information appears at the LOGAV pin(s) where it can be averaged with a capacitor connected to ground. The voltage at the pin is no more than a few hundred millivolts above or below ground.

The output transistor is run at a constant current. This is accomplished by connecting a resistor from the LOGAV pin to the negative supply. With  $\pm 15$  V supplies, a 1.5 M $\Omega$  resistor will establish a 10  $\mu$ A reference current in the transistor which is the middle of the detector's dynamic current range in dB. This is also about the optimum value for the dynamic range and accuracy.

The LOGAV outputs are buffered and amplified by unipolar drive opamps. A 39k-1k resistor network connected between the output, threshold pin (inverting opamp input) and ground provides an amplification of 40.

An attenuator from the output to the appropriate VCA control port establishes the control sensitivity.

## Applications of the 2120

The threshold control pin and the negative-going unipolar output are useful in dynamic filter, downward expander, and noise gating applications — see Fig. 3.

Adding a resistor from the opamp output to the positive supply will make the drive bipolar for compander circuits — see Fig. 4. The value of the resistor may be chosen to determine the maximum output from the control amplifier. By modifying this circuit with a couple of diodes, one can obtain a unipolar drive in the positive direction. This is useful in

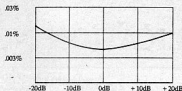

FIGURE 1A: VCA THD PERFORMANCE VS. GAIN (+104MV IN/OUT @ 1KHz).

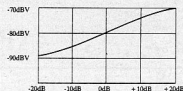

FIGURE 1B: VCA NOISE VS. GAIN (20KHz BANDWIDTH).

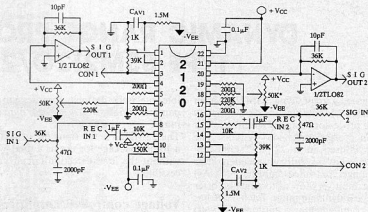

FIGURE 2: 2120 BASIC CONNECTION AT  $V_b = \pm 15$ V (CONTROL CIRCUITS UNCOMMITTED). \*OPTIONAL CONTROL FEEDTHROUGH NULL ADJUSTMENTS.

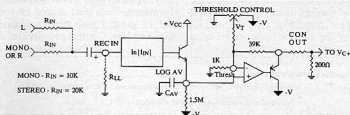

FIGURE 3: NOISE GATE/DOWNWARD EXPANDER CONTROL CIRCUIT.

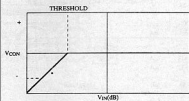

FIGURE 3A: TYPICAL DOWNWARD EXPANDER CONTROL CURVE. \*LOWER LIMIT CAN BE FIXED BY CONNECTING A RESISTOR RLL FROM REC IN TO GROUND.

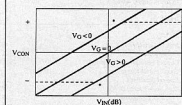

FIGURE 4A: TYPICAL COMPANDER CONTROL CURVES. \*UPPER AND LOWER LIMITS CAN BE ESTABLISHED BY VALUES OF  $R_{PV}$  AND  $R_{LL}$ , RESPECTIVELY.

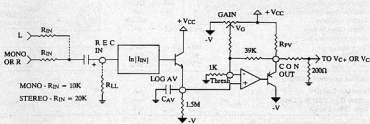

FIGURE 4: COMPANDER CONTROL CIRCUIT.

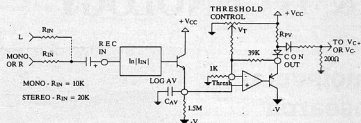

FIGURE 6: COMPRESSOR/LIMITER CONTROL CIRCUIT.

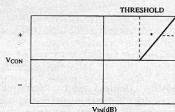

FIGURE 5A: TYPICAL COMPRESSOR/LIMITER CONTROL CIRCUIT. \*UPPER LIMIT CAN BE FIXED BY VALUE OF PULL UP RESISTOR (R<sub>PV</sub>) CONNECTED TO POSITIVE SUPPLY.

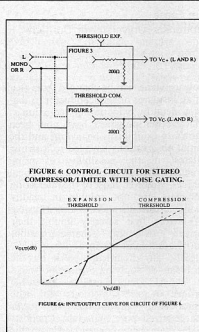

FIGURE 4: CONTROL CIRCUIT FOR STEREO COMPRESSOR/LIMITER WITH NOISE GATING.

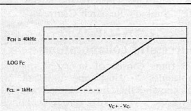

FIGURE 7A: DYNAMIC NOISE FILTER CONTROL CURVE. \*FILTER WILL CLOSE DOWN TO MINIMUM FREQUENCY WHEN INPUT SIGNAL AMPLITUDE IS BELOW THRESHOLD.

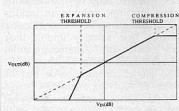

FIGURE 6A: INPUT/OUTPUT CURVE FOR CIRCUIT OF FIGURE 4.

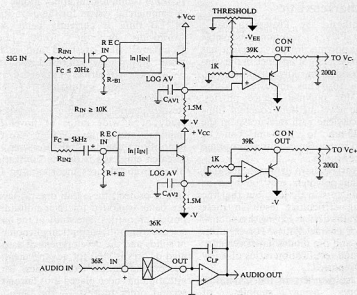

FIGURE 7: DYNAMIC NOISE FILTER CIRCUIT.

compressor/limiter applications — see Fig. 5.

The threshold control circuits shown in Figs 3, 4, and 5 can be used to control the signal level versus control voltage characteristic and/or the onset of control action in the case of Figures 3 and 5. The 1 kΩ and the series resistor from the threshold pin to the threshold control pot determine the sensitivity of the control.

The two control circuits can also be used in conjunction to produce composite control voltages. Fig. 6 shows such a circuit for a stereo compressor/limiter that also acts as a downward expander for noise gating. In the absence of a signal, the output noise will be determined by the opamp used in the output current-to-voltage converters if the expansion ratio is high enough.

Fig. 7 shows a control circuit for a dynamic filter that can be used in single-ended (non-encode/decode) noise reduction. Such circuits usually suffer from a loss of high-frequency content at low signal levels since the control circuit detects the absolute amount of highs present in the signal. Fig. 7 measures the relative amount of highs in the signal by effectively producing a composite control voltage which is the difference between the absolute amount of highs and the full audio band signal level. The values of the RB resistors establish a default signal level (for instance -30 dBV to -50 dBV) below which the filter(s) will start to close down to their minimum bandwidth, which should be about 1 kHz. This minimum cut-off frequency is determined by the value of the filter capacitor and the ratio of the RB resistors.

The 2120 can also be used in VCA fader automation systems to serve two channels. The inverting control port is connected through an attenuator to the VCA control voltage source\* and the non-inverting control port is connected to a Fig. 3 control circuit that senses the input signal level to the VCA. Above the threshold voltage which can be set quite low (say, -50 dBV or -60 dBV), the VCA operates at its programmed gain. Below this threshold the VCA will downward expand at a rate determined by the V<sub>EV</sub> control port attenuator. By keeping the release time constant in the 10 to 25 millisecond range, the noise floor modulation, which is -82 dBV maximum, can be kept inaudible.

\*The SSM2300 8-Channel Multiplexed Sample and Hold IC makes an excellent controller for VCAs in automation systems.

Further information on these products may be obtained from  
**Bourns Electronics Ltd • Hatford House • High Street • HOUNSLOW TW3 ITE • Telephone 01-572 6531**

## Big strides in molecular electronics research

by Dr Mike Petty and Professor Jim Feast  
Directors, Centre for Molecular Electronics, University of Durham



The recently established Centre for Molecular Electronics<sup>(1)</sup> at Durham University initially will have no formal structure and will act to support and promote research activities in this strategic and highly interdisciplinary subject.

Molecular electronics is generally concerned with the exploitation of organic materials in electronic and optoelectronic devices. Durham has a considerable expertise in this and an excellent research record; much of the work involves collaboration between members of the School of Engineering and Applied Science and the Department of Chemistry.

Examples of current research projects include organic conductors, pyroelectric materials, non-linear optics and Langmuir-Blodgett (LB) films.

The value of polymers in the established technologies of the electrical and electronics industries is based primarily on their utility as structural materials and/or insulators. There are many well-known examples including wire insulation, circuit boards, and instrument or device cases — where a wide range of thermosets and thermo-plastics have been used.

### Exciting new project

A rather less widely appreciated application of polymers is based on the formation of composite materials between essentially insulating polymers and conductive particles — carbon blacks or metals. These composite conductive polymers have been in use for well over a century and are the basis of several well established applications: for example, low conductivity materials employed in the discharge of static electricity; in shielding; in self-regulating heating tapes and thermal fuses; and in polymer thick film technology for electronics.

More recently, a lot of excitement and research activity has been generated by the report that the conductivity of the simple hydro-carbon homopolymer,

polyacetylene, can be changed from that of an insulator or semiconductor to that of a metal by oxidation or reduction. Many other polymers have now been shown to exhibit this behaviour and the initial observations have led to a strong interest in the possibility of using organic materials in electronic or optical devices. However, most of the interesting polymers are not soluble in readily available solvents and are also infusible — factors that severely inhibit their proper structural characterization, purification, and use in devices.

Clearly, any significant work on the problems of applying organic polymers as active components in electronic devices requires methods for the reproducible production of well-characterized pure materials. Chemists in Durham have concentrated on this aspect with some notable successes.

### Poor characteristics

The synthesis, by Professor Feast's group in 1979, of solution processible precursor polymer for polyacetylene has proved to be a major advance in the control of conducting polymer processing, which in turn has important consequences for polymer device physics. Using the novel method, coherent films of polyacetylene with thicknesses in the range 20 nm to 1000 nm can be deposited in configurations appropriate for device studies.

Several workers have demonstrated that conducting polymers may be used as semiconductors in devices, but that the processing difficulties result in these demonstrator devices having disappointingly poor characteristics. For example, Schottky and p-n diodes have been constructed and rectification ratios of a few hundred reported.

In contrast, workers in the Cavendish Laboratory, using samples of polyacetylene produced by the Durham route, have reported routinely obtaining rectification ratios of 500,000 for

Schottky diodes, and "textbook" behaviours for metal-insulator-semiconductor and field-effect transistor structures.

This work was supported by British Petroleum (BP) and the results referred to are part of those obtained in a collaborative study between the Universities of Cambridge, Durham and Sussex and BP's Sunbury Research Centre<sup>(2)</sup>.

### Successful collaboration

LB films consist of layers of organic molecules — just one molecule in thickness — that are assembled on solid surfaces. The LB process allows substances to be manipulated and fabricated at the molecular level; the term "Molecular Lego" is sometimes used. Fundamental physical and chemical processes may therefore be studied; the technique also has many possible technological applications.

A commercial system for the deposition of LB films is currently being sold worldwide by the Joyce Loebel Company<sup>(3)</sup> of Gateshead and is the result of a highly successful collaboration between Durham University, Imperial Chemical Industries (ICI) and Joyce Loebel.

Research currently in progress includes a study of a wide range of novel LB materials and an investigation into the deposition technique itself. However, the research emphasis is on the fabrication of electronic devices incorporating LB films.

In one project, these thin organic layers are being exploited for their non-linear optical properties. The study of the basic science of non-linear optical phenomena in solids and the development of associated devices is vital for advancement of telecommunication technologies. Most attention has been placed thus far on the second order process — the phenomenon responsible for second-harmonic generation — which occurs in inorganic insulators and semiconductors.

## Attractive features

However, there is a rapidly growing interest in organic materials, especially molecular organic crystals because of their very large non-linear coefficients. For example, MNA (3-methyl-4 nitroaniline) has a second harmonic optical figure of merit about 20 times larger than that of lithium niobate. For device fabrication purposes it is desirable to prepare the organic material in thin film rather than bulk crystalline form.

The main aim of this work is therefore to explore the possibility of using LB films in optoelectronics; the natural orientation features of monolayers, the degree of control over molecular architecture, and the precise definition of thickness and refractive index are all attractive features of this approach.

Other work is focused on the development of infrared detectors. The present generation of thermal imaging devices relies mainly on cadmium mercury telluride (CMT). Such devices are bulky, expensive and require cooling; in addition, they have a limited spectral sensi-

tivity. On the other hand, thermal detectors based on the pyroelectric effect have a response that is flat over a broad wavelength range, even when uncooled. It has been shown that the sensitivity of a pyroelectric detector is approximately proportional to the inverse of its thickness; however, electrical breakdown limits the minimum thickness to which conventional detector materials, such as poled polyvinylidene fluoride (PVDF), can be prepared. It would therefore be advantageous to fabricate a pyroelectric detector based on LB films.

## Ongoing research programmes

Pyroelectricity in thick samples consisting of alternate layers of fatty acids and fatty amines and in single monolayers of azo dyes has already been demonstrated. The aim of this project is to find novel materials which can be used to form pyroelectric devices of only a few monolayers thickness.

The foregoing represents only a few of the current research programmes at Durham. Other activities concern

biological membranes, liquid crystal devices, molecular recognition and sensors, and neutral networks. Molecular electronics is a very rapidly growing area of research within the United Kingdom. This has been recognized by the Government. Both the Science and Engineering Research Council (SERC) and the Department of Trade and Industry (DTI) have recently announced initiatives to support the work. This will greatly benefit Durham University and other groups in Britain.

1. University of Durham, Centre for Molecular Electronics, Science Laboratories, South Road, Durham DH1 3LE. Telephone: (091 374) 2389.

2. British Petroleum, Sunbury Research Centre, Sunbury-on-Thames TW16 7LN.

3. Joyce-Loebel Ltd, Dukeway, Team Valley, Gateshead, Tyne and Wear NE11 0PZ. Telephone: (091 482) 2111.

## NEW PRODUCTS

### Transistor Kit.

ELECTRONICS Hobby Centre have developed the MW transistor kit which combines electronics education with fun. The kit is available with PCB, components having cabinet of different colours, and technicolor instruction manual of nearly 50 pages. It is enclosed in a plastic laminated carton box of the size of 115 x 70 x 35 mm. The kit works on 3 V (2 penicill cells). The 3 mm LED that fluctuates as per the audio signal gives a fascinating look to the transistor.



M/s. Electronics Hobby Centre • F-37, Nand Dham Indl. Estate • Marol • An-dheri (E) • Bombay-400 059 • Phone - 636 6123.

### Telex Link

Using a Telex Link one can connect a personal computer to the telex line to edit and send message direct from the screen or from stored files. The Transmatic CTC 4000 runs in the background of normal computing tasks thus leaving the screen and printer free for other user functions. Outgoing messages can be edited and sent immediately or can be stored and sent automatically.

While the system is being used otherwise, messages are automatically acknowledged and stored safely. One can display them on the screen or print them out at will. Either way, there is no need to interrupt messages under preparation or any other job that is being done on the computer system. Further, the CTC 4000 keeps a log of all incoming and outgoing telex activity, with each event timed and dated by the system for upto 80 days.

There is also the facility to keep a directory of telex numbers frequently used, quickly referenced by simple abbreviation, which speeds up the sending of telexes and avoids any wrong numbers.

M/s. Transmatic Systems Ltd. • 9/64-1, Golf Links Road • Kowdiar • Trivandrum-695 041 India.

### Resistance Thermometer

The Chowdhry resistance thermometers are electrical thermometers with which temperatures between -220°C and 750°C

and, in special cases, upto 850°C can be monitored, controlled and recorded. Measurement is effected by determining the ohmic resistance of a metal wire used in the manufacture of element which is usually platinum Nickel or copper. Thermometers are generally required with 100 ohms resistance at 0°C. Elements having other resistance can also be manufactured. Measuring circuit is usually fed with 6 V.D.C. Elements are made of very pure metals, fully annealed after mounting to eliminate strain due to handling, resistance elements with platinum, nickel or copper can be manufactured on different formers such as mica, ceramic or glass. The thermometers can be supplied with single or double element in a common protecting tube. It can be used in 2- or 3-wire system. All elements, after proper insulation, may be enclosed in a suitable metal protecting tube of brass steel or stainless steel. The thermometers can also be provided with Thermowell. Also manufactured are Slot resistance elements from -50°C to + 150°C having platinum or copper element on laminated plastic or bakelite former. These elements are designed for temperature measurement in winding of electrical machines and surface temperature measurement.

M/s. Chowdhry Instrumentation Pvt. Ltd. • 110, Model Basti • New Delhi-110 005.

# HIGH-PRECISION DLF-BASED LOCKED FREQUENCY REFERENCE

by J. Bareford

This 10 MHz reference source for electronic clocks and laboratory equipment derives its stability of  $3 \times 10^{-6}$  from the powerful DeutschlandFunk (DLF) long-wave transmitter at 153 kHz.

The accuracy of a frequency standard locked onto the carrier of a transmitter is, in principle, only dependent on the accuracy at which the carrier is generated. In the case of a number of stations transmitting in the long-wave range (50 to 200 kHz), the stability of the carrier is derived from an atomic clock with extremely high precision. Examples of high-stability stations are DCF77 (see Ref. 1), Rugby MSF, Droitwich and DLF. Contrary to DCF77 and MSF, which are time-standard stations, DLF transmits an amplitude-modulated broadcast program. The stability of the daytime carrier at 153 kHz is  $5 \times 10^{-11}$  at a transmit power of 500 kW; that of the nighttime carrier is  $5 \times 10^{-12}$  at 250 kW. Fortunately, the transmitted signal is free from frequency and/or phase-modulated data services as implemented on DCF77 at 77.5 kHz.

The stability of the DLF carrier is better than almost any timebase used in electronic clocks and test and measurement equipment. The circuit described here is essentially a heterodyne receiver with an intermediate frequency of 3 kHz. The local oscillator and the intermediate frequency are both locked on to 10 MHz. In this set-up, a special type of phase-locked loop (PLL) circuit enables the ultra-stable 153 kHz carrier received from DLF to be used for controlling the frequency of a 10 MHz crystal oscillator.

## From 153 kHz to 10 MHz

The block diagram of Fig. 1 answers the question of how 153 kHz can be 'related to' 10 MHz. The central block is the voltage-controlled crystal oscillator (VCXO), which generates the 10 MHz reference signal. Two consecutive buffers clean and shape this signal, which is then taken through a band-pass filter before being fed to the output socket. The output signal of the first buffer is multiplied by a factor 1.5 and subsequently divided by 100 to give a digital signal of 150 kHz.

The Type SO42P integrated circuit at the input of the circuit mixes the received 153 kHz signal from DLF with the

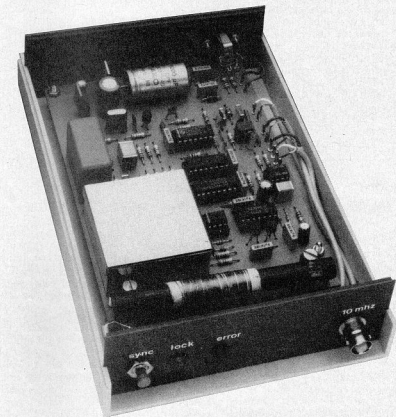

digital 150 kHz signal to give an intermediate frequency (IF) of 3 kHz, which is subsequently filtered in a band-pass section. The phase of this 3 kHz signal is compared with that of another 3 kHz signal, obtained by dividing the 150 kHz timebase signal by 50. The output of the phase comparator, which is actually a multiplier circuit, is passed through a loop filter with a cut-off frequency of 0.0003 Hz. The PLL error signal so obtained is used for controlling (i.e., correcting) the output frequency of the 10 MHz VCXO. In practice, the stability achieved with the prototype of the frequency standard, in the locked state, was measured as better than  $3 \times 10^{-6}$  within a period of 10 s.

The rather special configuration of the receiver ensures that short interference

on the received signal has virtually no effect on the stability of the output signal. For instance, an interfering pulse that results in an input frequency shift of, say, 1 kHz, results in an intermediate frequency shift that is 150 times smaller, causing negligible deviation of the 10 MHz ( $10 \times 10^6$  Hz) VCXO. For long-term interference, the VCXO should, of course, be controlled proportionally. The proposed structure of the receiver thus ensures that the 10 MHz output signal remains locked on to the received carrier from DLF, in spite of short-term interference, a feature that is not so simple to realize with a standard PLL.

## Circuit description

The circuit diagram of Fig. 2 shows how

the above concept has been worked out in practice. The 10 MHz VCXO is essentially formed by transistor T<sub>3</sub>, quartz crystal X<sub>1</sub> and variable-capacitance diode D<sub>5</sub>. The emitter of T<sub>3</sub> carries the analogue 10 MHz signal, which is converted to a digital level by gate N<sub>1</sub>. Buffer gate N<sub>2</sub> feeds the digital 10 MHz signal to RLC low-pass filter C<sub>22</sub>-L<sub>5</sub>-C<sub>23</sub> at the output of the frequency standard. The output signal is a 10 MHz sinusoidal signal that requires buffering if long cables and/or relatively heavy loads are connected. The output is, however, capable of driving a single equipment without a buffer. The connecting cable should be short and coaxial. Gate N<sub>1</sub> also drives a multiplier set up around N<sub>3</sub>, N<sub>4</sub> and tuned circuit L<sub>4</sub>-C<sub>59</sub>. The operation of the so-called *regenerative* frequency multiplier is basically as follows (also refer to the block diagram in Fig. 3). Pin 10 of N<sub>3</sub> is driven by the digital 10 MHz signal, and pin 9 by the signal developed across the tuned circuit. This resonates and sup-

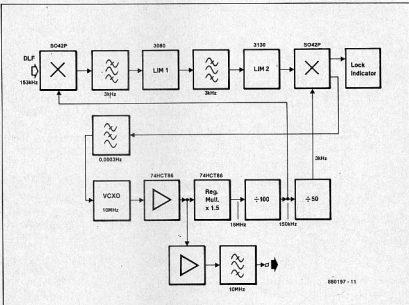

Fig. 1. Block diagram of the locked 10 MHz frequency reference.

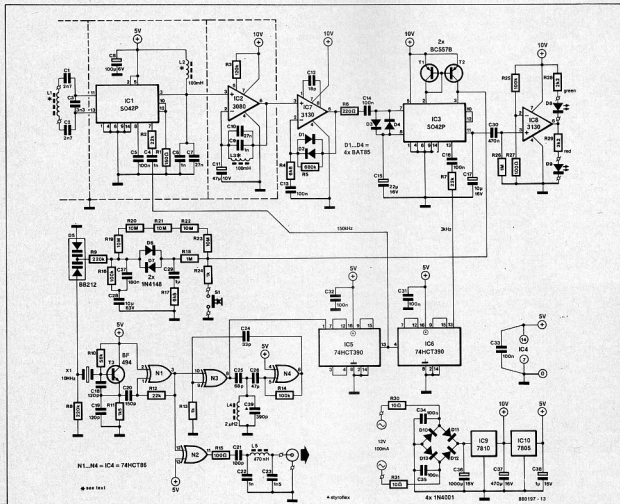

Fig. 2. Circuit diagram of the ultra-stable frequency reference, which derives its accuracy from the long-wave DLF broadcast transmitter at 153 kHz.



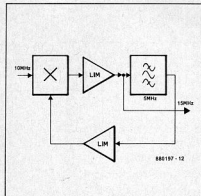
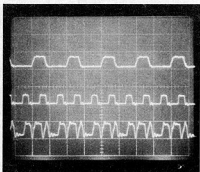

Fig. 3. Block diagram of one of the key circuits in the frequency reference: the regenerative frequency multiplier.

plies a 5 MHz signal which is digitized by gate  $N_1$ . The 10 MHz and 5 MHz signals are added by  $N_2$ , so that 15 MHz is available for clocking counter  $IC_3$ . The R-C network in the multiplier,  $R_{13}$ - $C_{24}$ , and a polystyrene capacitor in the tuned circuit,  $C_{39}$ , ensure correct phase relationship of the signals applied to  $N_2$ , so that only the 15 MHz sum frequency is generated.

Counter  $IC_3$  divides the 15 MHz signal by 100. The 150 kHz signal is applied to mixer  $IC_4$ , and to a second counter,  $IC_6$ , which is set up to divide by 50. The 3 kHz signal so obtained is fed to a second mixer,  $IC_5$ .

The signal from DLF induces a voltage in tuned circuit  $L_1$ - $C_7$  connected to the balanced inputs of the Type SO42P mixer,  $IC_1$ . The intermediate frequency obtained by mixing the received 153 kHz signal with that of the 150 kHz 'local oscillator' is filtered by  $IC_2$  and a tuned circuit,  $L_2$ - $(C_8+C_{10})$ . After amplification and clipping by  $IC_3$ , the 3 kHz signal is fed to multiplier  $IC_4$ , another



Oscilloscope photograph to illustrate the operation of the regenerative frequency multiplier. Upper trace: 5 MHz input; middle trace: 10 MHz input; lower trace: 15 MHz 'regenerated' output frequency. Note the phase relationship between the 5 and 10 MHz input signals.

Type SO42P. This stage compares the phase of the 3 kHz intermediate frequency with that of the 3 kHz timebase signal. The error signal produced by the comparator has a very low frequency, requiring a loop filter whose cut-off frequency is set to 0.0003 Hz ( $R_{19}$  through  $R_{23}$ ; 50 M $\Omega$ , and non-electrolytic capacitor  $C_{24}$ ; 10  $\mu$ F). The low-pass filter is only effective when the input frequencies of the phase comparator are almost equal, which results in small changes in the VCXO control voltage. With larger frequency differences, the control voltage has a much larger swing, so that  $D_6$  or  $D_7$  can conduct. When this happens, the response of the PLL becomes faster since the resistance in its R-C loop network is lowered from about 50 M $\Omega$  to 1 M $\Omega$ .

The VCXO control circuit enables the oscillator to be tuned correctly at only one side of the central frequency. If the voltage on  $C_{28}$  should rise beyond the normal tuning span of the VCXO, the PLL would have considerable difficulty returning to the locked state. Switch  $S_1$ , however, allows the VCXO frequency to be forced within the normal range, enabling the circuit to lock again. Fortunately,  $S_1$  will hardly ever need to be actuated once the PLL has locked on to the carrier from DLF.

A visual 'out-of-lock' indicator is set up around comparator  $IC_8$ , and LEDs  $D_8$  and  $D_9$ . When the PLL is locked, there is no alternating voltage at pin 11 of  $IC_8$ . This means that the voltage at pin 3 of  $IC_8$  is more negative than that at pin 2, so that the output of the comparator is low and the green LED,  $D_8$ , lights. When the PLL is actively correcting the VCXO frequency, the alternating voltage at pin 11 of  $IC_8$  causes the voltage at pin 3 of  $IC_8$  to rise above that at pin 2. The comparator toggles and the red LED,  $D_9$ , lights to indicate that the 10 MHz output frequency is not stable. The indicator LEDs flash at the rate of the error signal if the circuit is out of lock. In the locked condition, it may occasionally happen that one of the LEDs lights briefly as a result of modulation or interference.

The frequency reference is powered by conventional 5 V and 10 V regulated supplies. Networks  $R_{30}$ - $C_{34}$  and  $R_{31}$ - $C_{35}$  suppress mains-borne noise.

## Construction

Figure 4 shows the track layout and component mounting plan of the PCB designed for the frequency reference. For optimum stability of the reference, tinned screens must be fitted on to the board. For the location of these screens, see the photograph of the prototype in Fig. 5.

Do not replace the 10  $\mu$ F solid capacitor

## Parts list

Resistors ( $\pm 5\%$ ):
$R_1 = 150R$
$R_2, R_7, R_{12} = 22K$
$R_3 = 120K$
$R_4, R_{17} = 6K8$
$R_5 = 680K$
$R_6 = 220R$
$R_8, R_9 = 220K$
$R_{10} = 56K$
$R_{11} = 1K5$
$R_{13}, R_{24} = 1K0$
$R_{14}, R_{16}, R_{26} = 100K$
$R_{15}, R_{27} = 100R$
$R_{18}, R_{26} = 1M0$
$R_{19} \dots R_{23}$ incl. = 10M
$R_{28}, R_{29} = 2K2$
$R_{30}, R_{31} = 10R$
Capacitors:
$C_1, C_2 = 2n7$
$C_3 = 3n3$
$C_4, C_6, C_9, C_{22} = 1n0$
$C_5, C_{13}, C_{14}, C_{16}, C_{31} \dots C_{36}$ incl. = 100n
$C_7, C_{10} = 27n$
$C_8 = 100\mu$ ; 6 V; radial
$C_{11} = 47\mu$ ; 10 V; radial
$C_{12} = 18p$
$C_{15} = 22\mu$ ; 16 V; radial
$C_{17} = 10\mu$ ; 16 V; radial
$C_{18}, C_{19} = 120p$ ceramic NPO
$C_{20} = 150p$
$C_{21} = 100p$
$C_{23} = 1n5$
$C_{24} = 33p$
$C_{25} = 68p$
$C_{26} = 47p$
$C_{27} = 180n$
$C_{28} = 10\mu$ ; 63 V MKT (do not use an electrolytic type!)
$C_{29} = 1\mu$ ; MKT
$C_{30} = 470n$
$C_{36} = 1000\mu$ ; 25 V
$C_{37} = 470\mu$ ; 16 V; radial
$C_{38} = 1\mu$ ; 16 V; radial
$C_{39} = 390p$ polystyrene ('styroflex')
Inductors:
$L_1 =$ home-made inductor, wound on 10 cm long, 10 mm dia. ferrite rod; see text.
$L_2, L_3 = 100mH$ radial inductor with ferrite encapsulation; Toko Type 181LY-104 (Crickit stock no. 34-10402).
$L_4 = 2\mu H$ axial inductor.
$L_5 = 470nH$ (0.47 $\mu H$ ) axial inductor.
Semiconductors: $D_1 \dots D_4$ incl. = BAT85 (Cricklewood)
$D_5 = BB212$ (C- Electronics)
$D_6, D_7 = 1N4148$
$D_8 =$ green LED
$D_9 =$ red LED
$D_{10} \dots D_{13}$ incl. = 1N4001
$T_1, T_2 = BC557B$
$T_3 = BF494$
$IC_1, IC_3 = SO42P$ (Universal Semiconductor Devices; Cricklewood)
$IC_2 = CA3080$
$IC_4 = 74HCT86$
$IC_5, IC_6 = 74HCT390$
$IC_7, IC_8 = CA3130$
$IC_9 = 7810$
$IC_{10} = 78L05$
Miscellaneous:
$S_1 =$ push-to-make button.
$X_1 = 10$ MHz quartz crystal; 30 pF parallel resonance.
Ferrite rod: length approx. 10 cm; diameter 10 mm.
Mains transformer or mains adapter 12 V; 100 mA.
PCB Type 880197

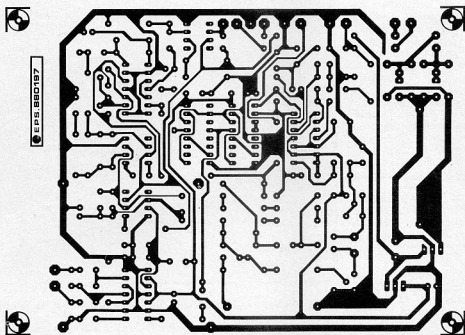
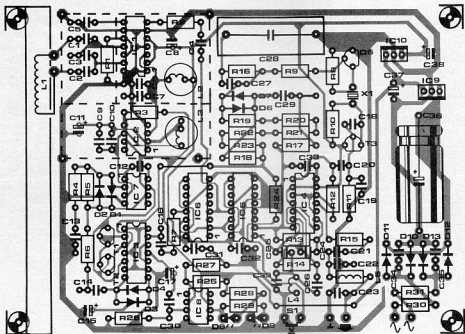

Fig. 4. Track layout and component mounting plan of the printed-circuit board designed for the frequency reference.

in position  $C_{28}$  with an electrolytic type. The quality factor of inductors  $L_2$  and  $L_3$  is critical and governs the use of ready-made, ferrite-encapsulated, 100 mH types from Toko.

The aerial coil is wound on a paper, paxolin or thin cardboard former of an internal diameter that enables it to be slid on to a 10 cm long ferrite rod of 10 mm diameter. The inductor is made from 150 closewound turns of 0.2 mm (SWG34) enamelled copper wire. The aerial circuit is tuned to 153 kHz by sliding the former over the rod until reception is optimum. The ferrite rod is secured on to the PCB with the aid of two plastic cable ties. The wire ends of the inductor are twisted and then connected to the PCB.

When high noise levels are anticipated in the long-wave band, it is recommended to make the aerial more directive by fitting it in a round aluminium or tin-plate holder as shown in Fig. 6. To prevent this short-circuiting the RF signal, it should have a lengthwise gap below the ferrite rod. Also note that the holder must not be closed at the ends.

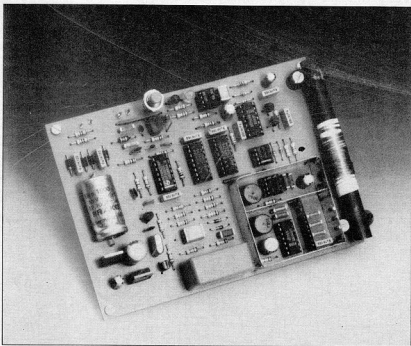

Fig. 5. Prototype board with aerial coil and screening installed.

## Testing and setting up

The locked frequency reference has only one adjustment: the aerial. Slide the former across the rod until a point is found where an oscilloscope connected to pin 6 of  $IC_2$  indicates maximum amplitude of the 3 kHz intermediate frequency. If necessary, rotate the board with the ferrite rod horizontally to maximize the received signal. The minimum amplitude for correct operation of the PLL is about 600 mV<sub>pp</sub> at pin 3 of  $IC_2$ . When an oscilloscope is not available, the aerial may be aligned until a clean 3 kHz sine-wave is heard in a high-impedance earpiece or headset. Depending on the tolerances of the capacitors used in the tuned circuit, it may be necessary to increase or decrease the number of turns by 10 or so. The aerial works best with the former about central on the ferrite rod.

The 10 MHz output on the printed circuit board is connected to a BNC socket on the front panel of the enclosure. Since the ferrite aerial is mounted on to the board, the enclosure should be an ABS rather than a metal type.

After powering up, the red light is most likely to light. After a short delay, both the green and the red LED flash rhythmically for a couple of seconds. Then, if everything is in order, the red LED goes out and the green one lights to indicate good reception. The output of the frequency reference then supplies an ultra-stable 10 MHz signal.

If reception is poor or marginal, as indicated by intermittent lighting of both LEDs or the red LED alone, rotate the

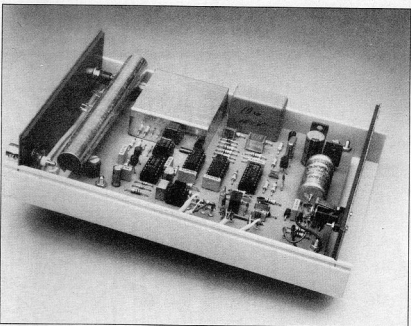

Fig. 6. The aerial can be given extra directivity with the aid of this construction.

unit so as to direct the aerial towards DLF.

✻

# HORN LOADING REVISITED

by R.M. Harris, B.Sc.

Horn loudspeakers provide good low-frequency performance and high efficiency, but are impractical for many uses because they are very large. However, R.M. Harris describes a design that is suitable for use in an ordinary living room.

The weakest link in any hi-fi system is undoubtedly the acoustical transducer or loudspeaker. Sound recording technology is reaching new levels of precision and noise reduction with digital recording and compact discs. Amplifiers can be perfected to almost any degree, if the price is right, with hitherto unheard of purity in terms of harmonic distortion and intermodulation products. In other words, it is possible to reproduce sound faithfully from DC to RF, but only in terms of electrical signals. For, while electronic technology has passed from thermionic valves through discrete transistors to integrated circuits, the loudspeaker has hardly changed in its essentials since its invention in 1925\*.

Since middle- and high-frequency propagation is characterized by small-amplitude sound waves, which eases most engineering problems, this article is confined to the problem of obtaining good, clean low-frequency sound reproduction.

Two physical principles account for most of the engineering difficulties at low frequencies. The first is that for a plane propagating sound wave the pressure,  $p$ , and particle velocity,  $u$ , are related in terms of the specific acoustic impedance of the medium (air):

$$p/u = Z_0 \quad [1]$$

where

$$Z_0 = \rho_0 c \quad [2]$$

in which  $\rho_0$  is the density of the medium and  $c$  is the velocity of sound in the medium.

At a point in space, the instantaneous particle displacement,  $y$ , of a sinusoidal sound wave of amplitude  $a$  and frequency  $f$  Hz, is given by

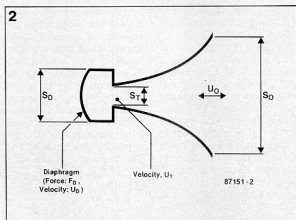
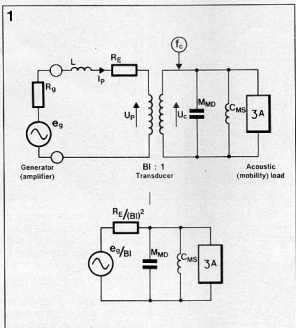

$$y = a \sin 2\pi ft \quad [3]$$

and the instantaneous velocity is

$$u = dy/dt = 2\pi a f \cos 2\pi ft \quad [4]$$

and the maximum velocity is

$$u = 2\pi fa \quad [5]$$

For a given sound pressure level—SPL—of  $p$ , the amplitude is given by

$$a = u/2\pi f \quad [6]$$

$$= Z_0 p/2\pi f \quad [7]$$

Both [6] and [7] simply state that

the amplitude increases as the frequency decreases.

The second principle is that at low frequencies the wavelength in air is much larger than the dimensions of the sound source. This results in the radiation of spherical wave fronts from what is, in effect, a point source. The specific acoustic impedance,  $Z_s$ , is not the same for diverging waves, as given by the general formula

$$Z_s = \frac{p}{u} = \frac{\rho_0 c k r}{\sqrt{1 + k^2 r^2}} \quad 90^\circ - \arctan kr \quad [8]$$

where  $r$  is the radial distance from the point source, and  $k = 2\pi/\lambda$ .

When  $kr \gg 1$  ( $r \gg \lambda/2\pi$ ), the magnitude of  $Z_s$  approaches the value for a plane wave ( $\rho_0 c$ ) with  $u$  in phase with  $p$ . For  $k\lambda = 1$ ,  $Z_s$  goes to zero and  $u$  tends to be in phase quadrature with  $p$ . The real part of  $Z_s$  (which is generally complex) falls to zero as  $r^2$ , which means that the mismatch between the transducer and the medium degrades in direct proportion to the square of the wavelength.

The corollary is that the speaker cone has to execute larger movements to maintain a constant SPL at lower frequencies if  $Z_s$  remains constant. If, however,  $Z_s$  (and in particular the real part of  $Z_s$ ) falls at lower frequencies, the situation is exacerbated. So, all effects included, the cone amplitude needs to vary as  $\lambda^3$  or as  $f^{-3}$ .

The foregoing general analysis clinches the central problem of designing for efficient bass reproduction. Large amplitudes are deprecated for moving-coil driver units: they introduce not only mechanical difficulties, but also distortion. It has been stated (Ref. 1) that any movement of the cone entails some distortion: the more it moves,

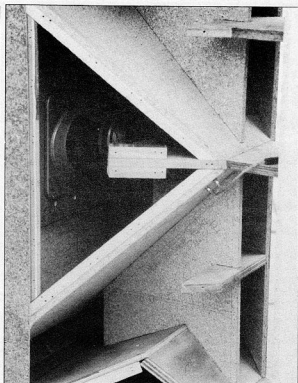
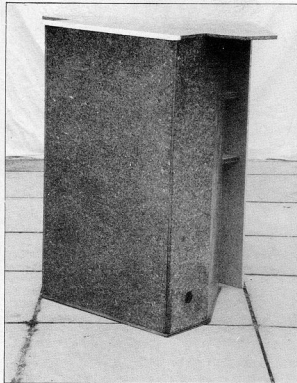

the worse the distortion. Unfortunately, the ear is adept at sensing very low levels of distortion, especially intermodulation distortion.

The concept of transforming electrical energy into acoustic energy introduces ideas of impedance matching and transducers. Without going into the intricacies of acoustics theory, the following simplified treatment of the method of "electrical analogy" may be helpful. The complete sound reproduction system from amplifier to air can be represented by an electrical equivalent circuit—see Fig. 1a. The constant-voltage generator has an internal resistance,  $R_s$ , which is typically  $0.2\Omega$  for modern amplifiers. The voice coil of the driver unit contributes inductance,  $L$ , and pure resistance,  $R$ . The essential function of the driver unit is that of energy transducer, which can be represented as a transformer with a turns ratio of  $B:1$ . The primary current,  $I_p$ , gives rise to a force  $f_p$  which, as it were, flows in the secondary circuit. The voltage induced back across the primary,  $V_p$ , reflects the velocity,  $u_c$ , of the voice coil. Thus,  $I_p = f_c / BI$  and  $V_p = BU_c$ .

The primary impedance,  $Z_1$ , is related to the secondary impedance,  $Z_2$ , as follows

$$Z_1 = V_p / I_p$$

and

$$Z_2 = u_c / f_c$$

so that

$$Z_1 = (BI)^2 Z_2 \quad [9]$$

The term  $BI$  is the magnetomotive force factor, which is measured in tesla per metre ( $T\ m^{-1}$ ).

Note that in the secondary circuit impedance is the inverse of the better known mechanical analogue where voltage corresponds to force and current to velocity. In the present system, known as the mobility system (Ref. 2), inertia becomes a shunt capacitance and spring resistance becomes a shunt inductance. Hence, the moving mass of the speaker is represented by capacitance  $M_{MD}$ , while the stiffness of the suspension and any enclosed volume (e.g. in infinite baffle designs) of air are represented jointly by inductance  $C_{MS}$ . The acoustic load is represented by  $A$ , the acoustic mobility, which is the reciprocal of acoustic impedance.

For maximum energy transfer, the blocking effects of the mechanical inertia and stiffness have to be minimized. In the

mobility system, this amounts to reducing the magnitude of  $\beta-A$  (particularly the real part) below the shunt admittances of  $M_{MD}$  and  $C_{MS}$ . Then,  $\beta-A$  will predominate in the secondary load.

The accompanying step is to reduce the size of the primary series impedances as reflected in the secondary—see Fig. 1b. At low frequencies,  $L$  may be disregarded. Considering the difficulty of achieving large enough values of acoustic impedance (i.e., low enough values of acoustic mobility,  $\beta-A$ ), every effort has to be made to reduce the moving mass and stiffness of the suspension. Furthermore,  $BI$  needs to be maximized to minimize the dissipative effect of  $R_e$ . The closed cabinet or infinite baffle

design reduces stiffness by the use of a large enclosed volume, increases  $Z_A$  by the use of a large cone, and then fails to reduce the moving mass (which includes a cylinder of air in front of the cone that is about a third of the cone radius deep). Such designs seldom achieve energy efficiencies much above 4%, in spite of decades of research.

### The horn as an acoustical transformer

For a sound wave propagating along an exponential horn, the particle velocity and pressure vary in proportion to the diameter of the horn. The specific acoustic impedance

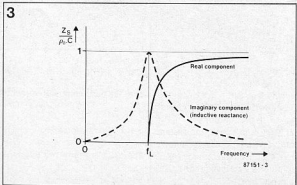

therefore remains constant. On the other hand, the acoustic impedance is defined as the pressure divided by the flow (= velocity times cross-sectional area). So, in the exponential horn, acoustic impedance varies inversely as the cross-sectional area. The horn transforms a small flow at high pressure in the throat to a large flow at low pressure in the mouth. Conventionally, the horn is driven by a diaphragm (e.g., the cone of a loudspeaker) of larger cross-sectional area,  $S_D$ , than that of the throat,  $S_T$ , as shown in Fig. 2. The force,  $F_D$ , acting on the diaphragm is related to the pressure,  $p_r$ , in the throat by:

$$F_D = S_D p_T \quad [10]$$

Also,

$$u_D = u_T S_T / S_D \quad [11]$$

where  $u_D$  is the velocity of the diaphragm and  $u_T$  is the particle velocity in the throat.

The mechanical impedance,  $Z_M$ , is defined as force per unit velocity. So, for the diaphragm,

$$\begin{aligned} Z_M &= F_D / u_D \\ &= (S_D^2 p_T) / (S_T u_T) \\ &= (S_D^2 / S_T) (p_o / u_o) \end{aligned} \quad [12]$$

where  $p_o$  and  $u_o$  are the pressure and velocity respectively in the mouth of the horn. For a horn of sufficient dimensions, the coupling to the outside world becomes 100% and the specific acoustic impedance at the throat approaches  $\rho_o c$ . Strictly, this is true only for an infinite horn, but for practical purposes is a horn of which the circumference of its mouth equals the wavelength of the lowest frequency to be propagated is adequate. Under these conditions, the mechanical impedance becomes

$$Z_M \approx \rho_o c (S_D^2 / S_T) \quad [13]$$

To equal this value of  $Z_M$ , an infinite baffle design would require a cone diameter of  $\lambda/\pi$ , where  $\lambda$  is the wavelength. At 40 Hz,  $\lambda = 8.28$  m, resulting in an impractical cone of more than 2.5 m in diameter.

The most serious restriction relating to low-frequency applications of horns is the cut-off

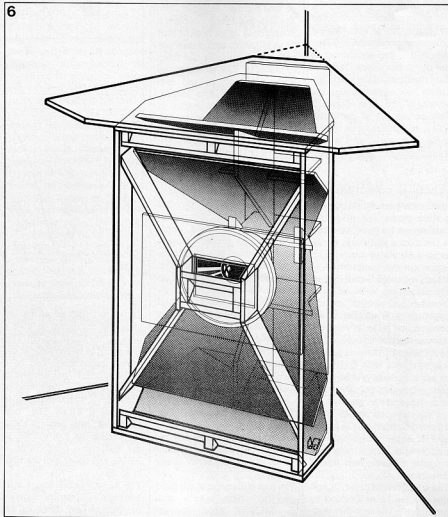
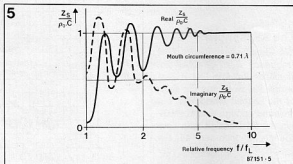
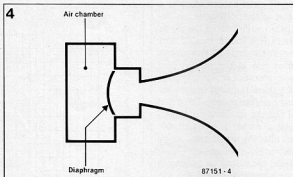

frequency,  $f_c$ , below which sound will not propagate. If the cross-sectional area of the horn varies with the distance,  $x$ , along the horn as

$$S_x = S_T \exp(mx) \quad [14]$$

the parameter  $m$ , expressed in  $m^{-1}$ , is called the flare constant. The low-frequency cut-off is given by

$$f_c = mc / 4\pi \quad [15]$$

For instance, if  $m = 0.3646 m^{-1}$ ,  $f_c = 40$  Hz.

For an infinite exponential horn, the real part of the throat impedance falls abruptly to zero at the cut-off frequency—see Fig. 3. The imaginary (reactive) part rises to a maximum at  $f_c$  and then falls asymptotically to zero. Above  $f_c$  it resembles a mirror image of normal capacitive reactance, which is the reason that it is often called negative capacitance reac-

tance. It also indicates the way to compensate it, namely by the series connection of a positive capacitive reactance of the same magnitude. In acoustics terms, this amounts to placing a compliant volume of air behind the diaphragm, enclosed in an airtight chamber—see Fig. 4. Note that this action is not in any way a frequency-selective tuning operation: in principle, it is rather a broad-band reactance annulling process.

The volume of the air chamber is calculated by multiplying the throat area,  $S_T$ , by the length in which the horn doubles its cross-sectional area, and then by 2.9. Typically, this volume is small compared with the enclosed volumes required for infinite baffle designs.

For finite horns, the throat-impedance curves exhibit a degree of periodicity, with the depth of the oscillations increasing as the horn is made shorter and thinner. Fig. 5 shows the behaviour of the real and imaginary parts of the throat impedance, computed by Olson, for a horn with a mouth circumference of  $0.71\lambda_L$ , where  $\lambda_L$  is the wavelength at the cut-off frequency. Once the flare constant and the size of the mouth have been decided, the length of the horn depends only on the size of the throat. Often, the desirable length is quite impractical at low frequencies.

## Practical constraints

Ideally, the horn would possess a wide mouth, say, 8.3 m circumference for good matching to the room at 40 Hz: this would entail a length of around 5 m. Some design compromise is clearly indicated if horn-loaded enclosures are to be adopted for semi-fixed or even portable applications. A number of actions can be taken to ease the dimensional limitations. The best-known of these is to fold the horn back onto itself once or twice to make a more compact, box-shaped structure. Less well-known, perhaps, is the method used by Lee in his catenoid design (Ref. 3), or that of PW Klipsch, in which the mouth of the horn is made to illuminate the room from one of its corners.

The effectiveness of the Klipsch method can be understood by considering the fact that plac-

ing a sound source close to a solid plane produces an in-phase image behind the plane. Similarly, a source located near the intersection of two planes gives rise to two images, and near a corner of a rectangular box three in-phase images accompany the source. The effect of placing the mouth of a horn near a corner is to quadruple the effective mouth area, which very usefully relaxes the earlier stated conditions on mouth circumference: it halves the circumference.

## The klipschorn

PW Klipsch described a *Low Frequency Horn of Small Dimensions* (Ref. 4) in 1941. His experimental work was cut short by the Second World War, but provided enough data to establish the final design with confidence. It included all the design improvements described in the foregoing section in an ingeniously designed cabinet pictured in Fig. 6.

The design cleverly conceals a doubly split reflex horn of over 1.5 m in length, and makes use of the room walls for two sides of the horn. The mouth of the horn is formed by two rectangular, vertical slots (including the contiguous images in the walls and floor) which make a phased array that helps to beam sound in the horizontal plane, and at the same time increases the specific acoustic impedance.

I shall not repeat or even summarize Klipsch's detailed analysis, but rather assume his measured results and apply them to the present project, which consists of a klipschorn enclosure and a Richard Allen CG12 driver unit. Klipsch used a mains energized Jensen 12, 12-inch driver, which enabled some acoustical measurements to be made via the voice coil terminals simply by switching on or off the magnetic field. The wedge-shaped air chamber has a volume of 64 l of which 9.8 l were taken up by the driver unit.

The chamber, by virtue of its pyramidal shape, was free of mid-range resonances and required no damping (which would reduce efficiency in any case).

The piston diameter of the cone (10.5 in) gave an area  $S_D = 0.0558 \text{ m}^2$ , which was re-

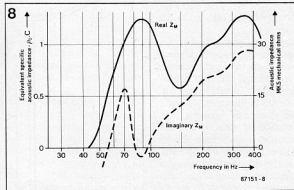
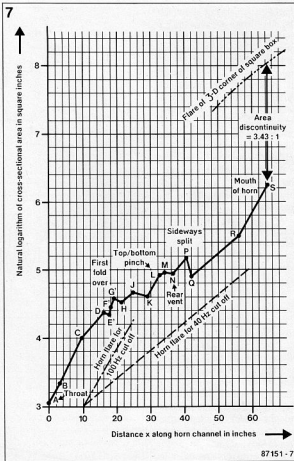

duced to  $0.0322 \text{ m}^2$  at the entrance to the throat to give a ratio  $S_D/S_T = 1.73$  in Eq. [1]. This was found to be too large at the lowest frequencies, and so a "rubber throat" was devised to give an effective throat area of  $0.0644 \text{ m}^2$  at 40 Hz, reducing to  $0.0322 \text{ m}^2$  at 100 Hz. The "rubber throat" was brought about by making the first section of the multi-flared horn cut off at 100 Hz, and the rest of the horn at 40 Hz.

The throat opened into a split horn with symmetrical channels pointing up and down for the

100 Hz cut-off section. The two channels folded around the top and bottom of the air chamber, constricting in the lateral dimension, but flaring in the vertical.

The 40 Hz cut-off flare constant was approximately maintained with the aid of a succession of short linear flares for ease of construction.

The sharp corner of the room was hidden by a fillet plate which deflected the now merged sound from upper and lower channels sideways between cabinet sides and walls.

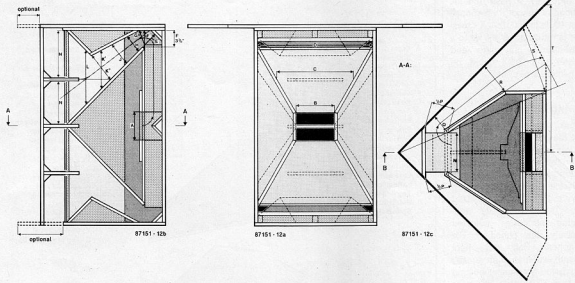

This time, the horn was split laterally and symmetrically if the cabinet was placed correctly. Fig. 7 shows the multi-furled profile, where the natural logarithm of the cross-sectional area has been plotted against channel distance.

### Calculated performance with a Richard Allen CG12 driver

Klipsch measured the acoustic impedance,  $Z_r$ , of the horn channel with and without the air chamber (which was external in his prototype). The air chamber certainly brought down the peaky reactive part of the impedance: the result, with chamber, is plotted in Fig. 8. More familiar to electronics engineers will be the Argand diagram in Fig. 9, where the measured acoustic impedance has been converted into its reciprocal,  $Z_r$ , "mobility ohms" as suited to the secondary circuit of Fig. 1b. The value of  $Re/(BI)^2$  has also been plotted for the CG12, where  $R_E=6.5\Omega$  and  $BI=13.7 \text{ T m}^{-1}$ . Maximum power is produced from a constant-voltage generator when  $Z_r$  equals  $Re/(BI)^2$ , and energy efficiency is just 50%. The degree of mismatch between  $Z_r$  and  $Re/(BI)^2$  corresponds to acoustical power loss. If  $Z_r$  exceeds  $Re/(BI)^2$ , efficiency does, indeed, rise, but not enough to compensate the drop in load current. If  $Z_r$  is

less than  $Re/(BI)^2$ , efficiency falls rapidly, with more power being dissipated in the voice coil's ohmic resistance.

The other parameters for the Richard Allen CG12, i.e., moving mass and spring constant, were inserted into the complete electrical network and the equations for acoustical power were solved with the aid of a personal TI-55-II programmable calculator. The resulting frequency response for a 10 V r.m.s. excitation has been plotted in Fig. 10. The maximum predicted output of 5 W may be compared with the 12.3 W that would be developed in an eight-ohm resistance. The 10 V r.m.s. corresponds to a 12 W personal amplifier: the audible effect for bass guitar and concert music is atypical of a domestic 12 W system. The author can credit Klipsch's claim to have achieved a ten-fold increase in loudspeaker efficiency over infinite baffle types. For comparison, Fig. 10 also shows the calculated performance of another driver unit (4 ohm), whose  $BI$  factor was much lower at  $3.35 \text{ T m}^{-1}$ . The lower excitation voltage of 4 V r.m.s. does not develop more than 5 W, but the point to notice is the much more peaky response, showing that the reflected voicecoil resistance has not been located centrally on the Argand diagram in Fig. 9. The klipschorn is capable of handling up to 100 W with less than 1% second-harmonic distortion at

40 Hz (which is mainly due to non-linearity of the air in the throat region (Ref. 5).

The roll-off below 60 Hz looks at first like an admission of failure, but remember that

Fig. 10, and Klipsch's own prediction for his Jensen 12A, is based on measurements made on a prototype design. When Klipsch evaluated the final cabinet design, he found that

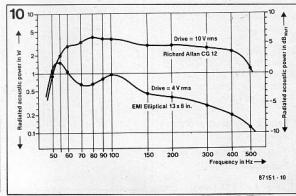
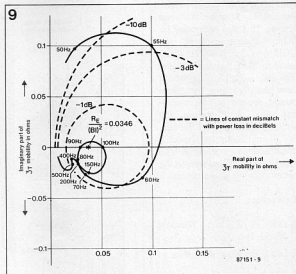



the whole characteristic was shifted fortuitously downwards in frequency, so justifying his claimed "smooth" response from 40 Hz to 400 Hz". A crossover is indicated at 400 Hz to a conventional mid-range and tweeter unit: both could be horn-loaded, of course.

## Construction

Before tackling this daunting task, the author made two scale models, a 1:8 in cardboard, followed by a 1:3.6 in 3-ply. The working model exhibited a roll-off below 180 Hz, which scaled down to 50 Hz for the full-sized unit. The intrinsically self-bracing structure indicated relatively thin panelling. For cheapness (but not light weight!), half-inch, high-density chip board was used, costing less than £9.00 in all. The truss and some fillets were made in marine 9-ply, while blocking, corner fillets, air seals, and so on were made out of oddments of hardwood and deal.

Joints were glued and screwed except for the access door—one large side panel—which was secured with 14 wood screws. This was necessary for fitting (retrospectively) the CG12 and for possible maintenance. With the door off, the top and bottom fillets would have been precariously unsupported, were it not for centre-line fins, which were the author's distinctive (cf. Jecklin, Ref. 6) modification to Klipsch's constructional designs—see Fig. 11, 12, and 13, as well as the accompanying photographs.

## References

1. Paul W. Klipsch, *Wireless World*, Feb. 1970
2. Leo I. Beranek, *Acoustics*.
3. Abraham B. Cohen, *Hi-Fi Loudspeakers and Enclosures*, 2nd Ed., Newnes Butterworth, London, 1975
4. P.W. Klipsch, *A Low Frequency Horn of Small Dimensions*, *Journal of the Acoustic Society of America*, Vol 13, pp 137-144 (1941)
5. Rocard 1933 cited in Moire's *Acoustics*
6. J. Jecklin, *Wireless World*, Febr. 1969

\* C.W. Rice and E.W. Kellogg

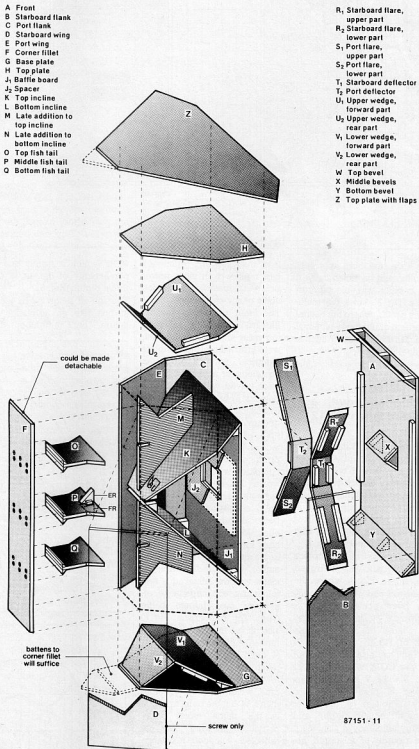

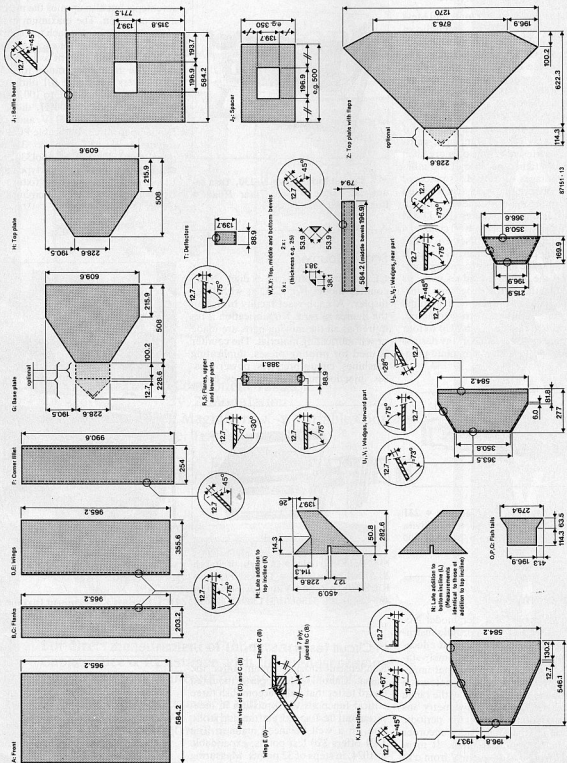

## Precision Digital Multimeter

PREMA (Prazision Electronic und Mess Anlagen GmbH) of Fed. Republic of Germany offer seven high accuracy 6½-digit resolution DMMs in a range. The top-of-the-line-DMM 6031 A has a ohms stability of 2 ppm for 24 hours, and accuracies of 0.07% for AC volts, 0.005% for Dc and 1% for AC currents. Temperature tolerance is 0.05°C IEEE 488 bus interface is a standard feature. DMM 6031 A has a 10 gigaohm input resistance. A series rejection of more than 100 dB is attained because of the inherent advantages of PREMA's patented multiple ramp integration synchronised by PLL to the mains frequency, and advanced shielding techniques. The DMM can be fitted with an inbuilt 20 channel 4 pole scanner (thermal offset 1 μV) for use in multi-point measuring systems. It has a wide scope of data processing operations on the measured values using its set of 20 mathematical programs. Functions include 8th order polynomial linearisation, non-linear, trigonometric, and statistical functions, etc. Up to four programs can be cascaded in any desired sequence to give a new compound program.

over-range indication. The unit is housed in an elegant moulded cabinet and weights less than 1.5 kg.

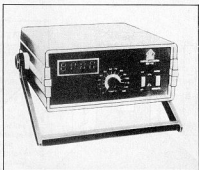

M/s. Puneet Industries • H-230, Ansa Industrial Estate • Saki-Vihar Road • Bombay-400 072 •

## Stroke Counter

CE Industries offer the 5 digit stroke counter model No. CSO30 with large display. A knob reset facility brings all the figures to zero. No lubrication is required as all the moving parts are made of self-lubricating material. The counter is used for printing presses, duplicating machines, circuit breakers, power presses, injection moulding machines, etc.

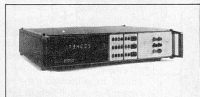

Electronics Engineering Services • 231 Keytuo Industrial Estate • Kondivita Road • Andheri (East) • Bombay-400 059 •

## Digital pH/mV Meter

Puncet 3½ digit PH meter model No. PH-11D is a LED type portable instrument for laboratory R&D, and educational institutions. It has extremely stable DC amplifier with high input impedance. It provides manual and automatic temperatures compensation in the range of 0°C to 130°C. It has asymmetry and slope correction controls for periodic calibration. It also provides recorder output and titration facilities. It measures pH from 0 to 14 and mV from 0 to ± 1999 mV with automatic polarity and

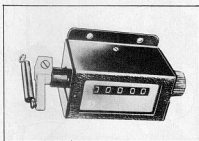

M/s. Sai Electronics • (A Divn. of Starch & Allied Industries) • Thakor Estate • Kurla Kiron Road • Vidyavihar (West) • 400 086 • Ph: 5136601/5113094/5113095

## In-Circuit Tester

Kandenstu Ltd. of Japan, offer the Fussa, Cabol 3301, a parts mounted board tester that helps accomplish three critical functions viz. precision in measurement, test speed and analog isolation, in a well balanced manner. The 3301 offers 320 test points, expandable to 1024, in steps of 32 points. Measuring speed for short test is 3 seconds/320 pin.

Maximum measuring steps are 2048 (each measuring step tests a component) at the speed of 15 ms per step. COBOL 3301 features automatic guarding facility which not only simplifies complex measurements but also uprates the measurement precision. The maximum number of guarding points for each test step is 15 with guarding points for each test step is 15 with guarding current as high as 100 mA. The measuring range for Cobol 3301 covers, resistance 0.1 ohm to 100 Mohm, capacitance 1 pF to 100,000 mF, inductance 1 uH to 100 H, diode and transistor 0.1 V to 2.0 V and Zener Diode up to 40 V. Applicable PCB measurement is 450 mm x 350 mm (maximum). The Fussa Cobol3301 range consists of: Gorilla for press type fixture, Elephant for vacuum type fixture, and Dragon automatic feed in-circuit board tester.

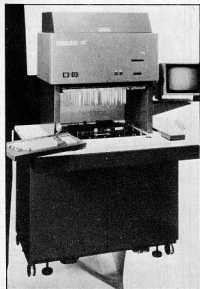

HCL Limited • Instrument Division • G-5 & 6 Vaikunth • 82-83 Nehru Place • New Delhi-110 019 •

## Instrument Cooling Fan

Engineered for instrument cooling application, the EBM compact fans are available in a range of sizes from 50 x 50 to 172 mm in 110/220 V Ac as well as 12, 24, 48 VDC (brushless motor). The unique external rotor motor with aerodynamic blades ensures a high performance with maximum air displacement in restricted space. To ensure minimum vibration, minimum noise and long bearing life, the fans are dynamically balanced as per VDI 2060 02.5.

Larger axial/radial instrument cooling fans are also available for use in UPS, thyristor drives, induction heating panels, computers, AC/DC converters, etc.

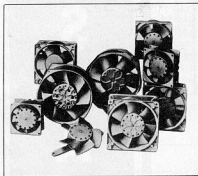

M/s. Nadi Airtechnics • P.O. Box 1939 • No. 2, Errabalu Chetty Street • Madras-600 001.

## Maintenance Kits

SAFEGARD is a complete range of maintenance kits in handy aerosol cans, providing quick solution to engineering, quality control, maintenance and repair problems, it is a aid. The all purpose acrylic protective spray eliminates arcing and corona in high voltage section, waterproofing exposed wiring, and insulating exposed electronic parts. Contact Cleaner cleans contacts, restoring the original efficiency of precision equipment. DPL Moisture Displacer provides long term, protection against moisture and corrosion. Dust Remover Spray instantly removes microscopic dust and lint.

Electronic Degreaser is suitable for cleaning precision instruments, electronic circuitry and electrical controls.

Freeze it Coolant locates thermal intermittents and defective components in electronics. Flux-Off (non-reactive) removes rosin, flux and ionic soils from electronic assemblies. It is useful in cleaning glass, metal and plastic when particulate removal is of concern. Flux-Off (extra strength) removes activated and non activated rosin, flux, dirt, grease and contaminants from electronic assemblies, without harming delicate components. All Purpose solvent/degreaser is a pure solvent for heavy duty cleaning. It dissolves heavy soils of grease and other contaminants fast.



Accra Pac (India) Pvt. Ltd. • 917, Raheja chambers, • Nariman Point • Bombay-400 021 • Tel: 244074, 234409, 2043661 •

## Apparatus for Cement Testing

An apparatus from Western Electronic Enterprises is based on photo-electric system, and takes hardly two minutes to determine the % of SO<sub>3</sub> in cement. It operates on single phase 50 cycle AC and is provided with a double light intensity meter for more accuracy in results.

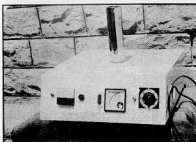

M/s. Western Electronic Enterprises • Sector 'D' 95, Shastri Nagar • JODHPUR-342 003

## CNC PCB Drilling & Routing Machine

Instrument Research Associates manufacture in technical co-operation with Dorniver Ltd of UK, a single spindle manual tool change CNC PCB drilling and routing machine suitable for producing PCB of 24.4" x 18.5". The machine employs a dedicated computer for both programming and drilling/routing. It consists of a closed circuit TV for programming a film or artwork and drill mechanics. CNC controls consist of a Joystick and a set of 20 keys with simple English description of instructions to enable even an untrained operator to programme the machine. After the programming is completed automatic checking and editing is done and prototype could be drilled. The final data, after corrections if any, is loaded on to an audio cassette using the data tape recorder of the machine.

For drilling, the camera is removed and the stack of three PCBs is installed on the drilling table and the high speed spindle which can be programmed up to a speed of 60,000 RPM is commended to drill at the desired speeds. Even feed rate is programmable depending on the height of the stack, material and drill sizes. After one set of programmed holes are drilled, the machine stops and an audible beep is given by the machine, to enable change of drill bit.

A feature is the auto self-centring on pad position (ASCOPP) capability. The machine works on 230 V single phase supply and consumes 1 KVA and does not require any external air supply.

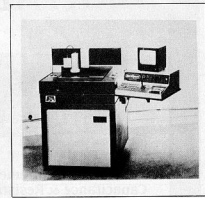

M/s. Instrument Research Associates Pvt. Ltd. • P.B. No. 2304 • 288, Magadi Road • Bangalore-560 023 • Phone: 350830.

## NEW PRODUCTS

### Isolated Power Semiconductor

Silicon Power Electronics, Pune have developed a range of isolated multi-component power semiconductor packs. These packs include single phase bridge rectifiers (four diodes) of 6 to 60 A, three phase bridge rectifier (6 diodes) of 25 to 50 A, thyristor modules of 25 to 100 A (av), and thyristor diode modules of 15 to 100 A, all up to 1,600 volts PIV.

All these products undergo isolation test of 2500 VAC from body to active terminal. Apart from occupying less space in electronics instruments these isolated packs are characterised by other features: the number of bridges or modules can be mounted directly on chassis or one heat sink; most of the terminals are screw-nut type and soldering is avoided wherever possible; as a number of devices are internally connected less hardware is required; and the body being isolated from active terminals, it becomes shock-proof. Applications are for AC/DC conversion and controlling power supplies, UPS systems, control panels, stabilisers, and conveyor systems in computers, cement, chemical, steel autobelies, sugar, pipe and other more industries.

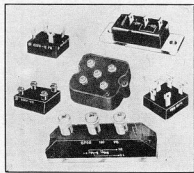

M/s. Amar Radio Corporation • 11/1, T.P. Lane • S.J.P. Road • Bangalore-560 002 •

### Back-Up Power Supply

Jivan offer the Data Intact, a back-up supply during power failure, designed as an interface between PC/XT/AT with printer, sophisticated electronic equipment and electric supply line. The instrument has a typical transfer time of less than half a cycle. A back-up time of 2

hours is available for personal computer on 24 V/40 AH battery. High efficiency and regulation is obtained using PWM technique. Inbuilt battery charger is provided for boost as well as trickle charging. The unit is protected against reverse battery connection. Audio/visual announcement is available for low battery voltage. In built electronic solid state voltage stabiliser is optional.



M/s. Jivan Electro Instruments • 394, GIDC Estate • Makarpura • Baroda-390 010 •

### LED Metal Module Indicator

BINAY have developed light emitting diode metal module indicators, which are similar in construction to neon jewel light indicators but use an LED as the light source. These LED modules are available in all voltages up to 230 VAC or DC. A variety of power input methods is also available by means of flying leads, solderable tags, or a unique coaxial jack-and-connector system for easy replaceability.

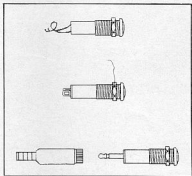

M/s. Binay Electronics and Electricals • 34/1 P, Ballygunge Circular Road • Calcutta-700 019 • Tel: (033) 478681 •

### Ultrasonic Pest Repeller

The Innosys electronic ultrasonic pest repeller: Model 2000 is effective over an area of 2000 cu. feet. The device emits high-frequency sound waves that drive pests away without killing them. Over a period of time the area under operation is completely rid of such pests. Although the sound waves emitted are unbearable to pests they are completely harmless and inaudible to human beings.



M/s. Innosys Electronics & Systems Pvt. Ltd. • A-2/174, Shah & Nahar Industrial Estate • Dhanraj Mills Compound • Lower Parel (W) • Bombay-400 013 •

### Multilingual Terminal

NITEL have introduced data processing and computerisation facilities in regional languages. In addition to the range of IBM compatible PCs offered, they now manufacture a multilingual terminal with design and knowhow from Department of Electronics/IIT Kanpur. The multilingual terminal (MLT) is offered in two versions either as a PC based or stand alone. A facility to undertake word and data processing in English, Hindi or any of the other 13 regional languages is offers. The multilingual terminals are based on powerful MC68000 microprocessor having a 128 KB dual ported memory (RAM), transliteration facilities, and ability to run packages under DOS in Indian languages.

M/s. National Information Technologies Limited • 153, Zone 1 • Maharana Pratap Nagar • Bhopal 462 011 • Phone: 61721 •

## NEW PRODUCTS

### DC-Regulated Power Supply

Puneet offer a Dc-regulated power supply in 2 models DC-21 and DC-22 with output varying from 0 to 30 V and current from 0 to 20 A. The instrument incorporates continuous current and voltage limiting. It has short circuit protection for indefinite period of short circuit. It is engineered for high degree of load and line regulations. The Model DC-21 is a single output unit and DC-22 a dual output supply which can be used in independent or tracking mode. They are suitable for use in production line, laboratories, R&D departments and educational institutions. Regulated power supplies with specific output voltage and current values are also made.

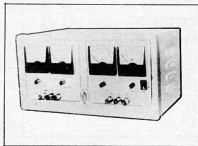

M/s. Puneet Industries • H-230, Ansa Industrial Estate • Saki-Vihar Road • Bombay-400 072 •

### Photo Control Unit

Instron Photo Electric Control Device, manufactured out of solid-state light source and solid-state device, is suited for automatising packaging machines. It provides reliable operation with extremely less ambient light effect. It is useful for detection of photo registration mark on packing material with the help of reflection scanner to provide instant signal for subsequent operation. The instrument is suitable for form, fill and seal machines; biscuit wrapping machines; tube filling machines; etc.

Sensitivity of scanner can be adjusted with a broad-band multi-turn control potentiometer. The adjusted switching point will not be influenced by ambient light, vibration temperature or voltage variations. The scanner has various colour combination sensing capabilities. The machine control can be effected through an electromechanical relay.

Various types of logic functions such as timer for action delay, quenching etc. to suit a variety of packaging machines can be provided.

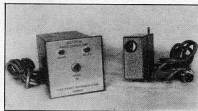

Electronics Instrumentation • 11, Saptrang • St. Anthony Street • Kalina • Bombay-400 029.

### Thermocouples

Chowdhry offer thermocouples for various applications and conditions having all standard pairs for use from -200°C to + 1600°C. The Thermocouples manufactured in different lengths, have protecting sheaths of different materials as per requirements. The connecting head is die-cast aluminium having bright chrome-plating. Protecting tubes are fabricated or machined from barstock. Special purpose thermo-couples for salt bath, molten metals; lock (for PVC/rubber etc.) pin disc (for hot surface), and bow types are also manufactured.

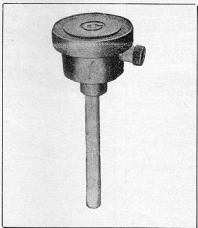

M/s. Chowdhry Instrumentation Pvt. Ltd. • 110, Model Basti • New Delhi-110 005 •

### Universal Bridge

Ando Electric Co. of Japan offer the LCR6 universal bridge which provides

high speed measurements of resistance, capacitance and inductance values and tan of capacitors. It has a built-in 1 kHz oscillator. An external oscillator can also be used for measurements in the 50 Hz to 19 kHz range. External DC bias can be superimposed without affecting the accuracy of measurements. The range of resistance that can be measured that can be measured is from 2 to 50 Mohms, that of capacitance from 5 pF to 200 mF, and of inductance from 5  $\mu$ H to 200H Tan for serial equivalent circuit is from 0.2 to 200%. The accuracy is within  $\pm 0.5\%$  for all the parameters.



Murugappa Electronics Ltd. • Agency Division • 29, Second street • Kamaraj Avenue • Adyar • Madras-600 020.

### STD Barring Device

Industrial & Trade Links offer an STD barring device based on C-MOS technology. The device is Self-Powered and needs no battery cell. An 3 position Godrej lock controls STD as well as local outgoing calls without affecting the incoming calls. Red LED glows to indicate that the device is properly connected. Green LED starts flickering when somebody tries to misuse the telephone. Adaptable to all types of phones or exchanges, including Plan 103, the device controls from pole, exchange and cordless phones too.

Industrial & Trade Links • H.O. : 62 'C' Wing • Mittal Court • 224, Nariman Point • Bombay-400 021 • Tel: 204 19 36

## NEW PRODUCTS

### PCB Relays

ERNI Elektroapparate GmbH of Fed. Republic of Germany offer miniature relays suitable for direct mounting on printed circuit boards. The relay contacts are available in hard silver, gold, or silver-cadmium-oxide metals to meet different industrial requirements. The relays have double contacts which ensure good contact for every operation. The contacts are enclosed in a transparent polycarbonate housing which provides protection from external influences.

Monostable relays with 1, 2, or 4 change over contacts and bistable relays with single changeover contacts are available normal (unsealed) version and sealed version. The latter offers the possibility of flow soldering and/or ultrasonic cleaning. The relays have applications in controls and industrial electronics area.

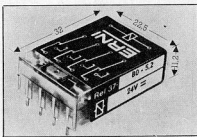

M/s. A.T.E. Limited • Electronics Division • 36 SDF II, SEEPZ • Andheri (E) • Bombay-400 096 • Phone: 6300195 • Telex: 011-79080 DIP IN •

### Direct Reading Dosimeters

Dosimeter Corporation, USA manufacture a range of dosimeters, hermetically sealed for consistent readings under a broad range of environmental conditions. Low energy models have thin walls over chamber area which enable low energy X-rays to penetrate the chambers.

These dosimeters meet ANSI specifications N13-5-1972 and are manufactured and tested to ANSI specification N322-1977. These provide for the Health physicist and every occupational exposed worker a continuous and immediately accessible monitoring of radiation exposure.

Models having range of radiation Detection - Gamma and X-rays 80 Kev to Cobalt 60 energies and 35 Kev energies and operating ranges 200 mR to 600 R are available.

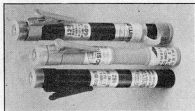

M/s. Electronics Instrumentation • 11, Saprang • St. Antony Street • Kalina • Bombay-400 029 •

### Programmer

Trica Engineering & Control Instruments has come out with a programmer for 8748, 8749, 8751. The programmer is an adapter to your development system such as Microfriend I or Microfriend II or any other. For further information contact, Mr. V.M. Barve, Mohan Building, Laxmi Chawl, Room No. 6, J.S. Road, Bombay-400 004. Tel No. 352833.

Trica Engineering & Control Instruments • 162/43 Mohan Bldg. • Fourth Floor • J.S.S. Road • Bombay-400 004 • Ph. 35 82 67

### Ribbon Reinking Machine for Computer user,

TRACK ENGINEERS have developed an inking machine, Track Inker, for computer and electronic typewriter ribbons. Useful for reinking all types of Fabric Ribbons at the user's location, the machine is fully automatic and tabletop and supports all types of ribbon cassettes irrespective of ribbon length and width. It consists of a base with an electrical drive and ink reservoir, Ink is transferred to the ribbon via a capillary mesh which ensures even ink distribution. The ink used is a special type called dot matrix ink and is supplied alongwith the machine.

It is said that the same ribbon can be reinked 25-30 times without any deterioration in quantity. The machine comes in five models, all ribbons, including line printer ribbons, are also covered.

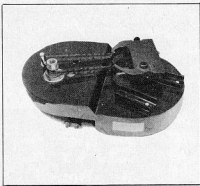

Track Engineers • 187/5225, 'Sanmati' • Pantanagar • Ghatkopar (E) • Bombay-400 075 • Phone No. 362111, 381989 •

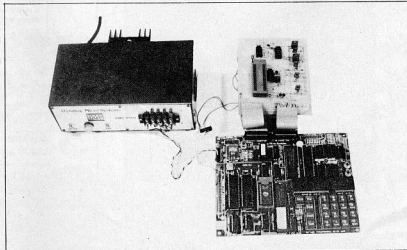

## RECORDING/PLAYBACK AMPLIFIER

April-1989 page no. 4.55

Fig-1 Suggested track assignment on a 4-track head is wrongly printed, it should be as following

A = slide change track

B = not used

C = track R

D = track L

ADVANCED VIDEO LAB	5.69
AMERICAN COMPONENTS	5.71
ARADHNA ELECTRONICS	5.70
APEX ELECTRONICS	5.08
ATRON ELECTRONICS	5.69
BMP MARKETING	5.71
BPB PUBLICATION	5.67
COMTECH	5.08
CYCLO COMPUTERS	5.14
DEWAN RADIOS	5.04
ELECTRICAN INSTRUMENTS LAB	5.03
GALA ELECTRONICS	5.65
GRAFICA DISPLAY	5.65
G. S. ELECTRONICS	5.71
INDU ACCOUSTICS	5.14
J.M. ENTERPRISES	5.06
KAYSONS RADIOS	5.69
KIRLOSKAR ELECTRODYNE LTD	5.63
LEADER ELECTRONICS	5.08
MECO INSTRUMENTS	5.19
NEW AGE ELECTRONICS	5.69
OSWAL ELECTRONICS	5.68
PARVAIL RADIO	5.70
PIONEER ELECTRONICS	5.06
PRECIOUS ELECTRONICS	5.60
PK & LK	5.06
SIMPTRONIKS	5.71
SUPER TRANSFORMERS INDUSTRIES	5.69
THANTIA ELECTRONICS	5.68
TELETONE RADIO	5.14
TOP TOOL PVT LTD	5.04
UNLIMITED ELECTRONICS	5.65
VARIANT ELECTRONICS	5.04
VASAVI ELECTRONICS	5.61
VIKAS HYBRID	5.15
VISHA ELECTRONICS	5.09
YABASU GRAPHICS	5.13

elektor

INDIA

Subscription  
Order

Name

--	--	--	--	--	--	--	--	--	--	--	--	--	--	--	--	--	--	--	--

Address

--	--	--	--	--	--	--	--	--	--	--	--	--	--	--	--	--	--	--	--

Pin Code

--	--	--	--	--	--	--	--	--	--	--	--	--	--	--	--	--	--	--	--

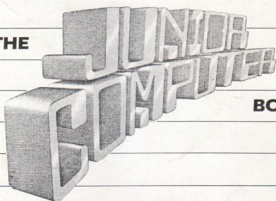

**DO IT YOURSELF****THE****BOOK****LEARN-BUILD-PROGRAM**

the practical introduction  
to a powerful system

Price  
Rs.50.00  
Available at  
all leading  
book shops.

The Junior Computer book is for anyone wishing to become familiar with microcomputers, this book gives the opportunity to build and program a personal computer at a very reasonable cost.

The Indian reprint comes to you from

**elektor** Group

Send full payment by  
M.O./I.P.O./D.D. No Cheque Please.  
Packing & Postage free

to: **elektor ELECTRONICS PVT Ltd.**  
52-C, Proctor Road, Grant Road (E),  
Bombay-400 007.

